

General Information

The sound system is available in two versions: the Base System, and the Premium System.

The Base System comprises a radio, cassette tape player optional compact disc (CD) player and door mounted speakers.

The premium system has the CD player fitted as standard, extra speakers mounted in the doors and sub-woofers mounted in the parcel shelf (coupe) and rear quarters (convertible). Both systems have an FM aerial and an AM aerial telescopic rod aerial. An additional feature of the Premium System is digital signal processing (DSP) which enhances sound quality in two ways: sub-woofer control and optimising sound to occupant positions.

The system is operated by the controls on the fascia panel, and the controls on the left-hand side of the multi-function steering wheel (where fitted). The control panel has an alpha-numeric display which provides detailed information, including text messages, relating to the operation of the unit.

Security code number (United Kingdom and Europe)

This unit is protected by an anti-theft security code. If power to the radio drops to 5 volts or less (dead battery), or there is a power interruption/disconnection, the radio display will indicate **CODE** after a short delay. At this point the radio will not operate until you have re-entered the correct security code.

The four digit code for your radio is listed on the two radio security cards supplied with the vehicle. Enter the code by using the pre-set buttons **1** to **9** and a 'beep sound' occurs. If the code is not properly entered, then begin the code entry again, starting with the first digit. If the code is not properly entered after three successive attempts, the radio will not accept any entry until it has been left for one hour in the **ON** position; the radio will accept three further entries.

Should you lose your radio security card, contact your Jaguar Dealer, who, for security reasons, will require proof of vehicle ownership.

1-2 Introduction and controls

Radio cassette player controls

Key

1. ON/OFF switch and volume control.
2. Mode button.
3. Cassette tape eject button.
4. Programme type (PT) and phone send and end button (United Kingdom and Europe).
5. Phone memory recall button.
6. Dolby B noise reduction (cassette mode) preset and phone key pad 1.
7. Programme change button (cassette mode) preset and phone key pad 4.
8. Preset buttons and phone key pad.
9. Radio tuning controls, cassette tape forward and rewind controls, CD player forward and reverse controls and seek function for all modes.
10. Auto memory (A-MEM) and phone key pad 0.
11. Traffic Information and Radio Data System (TA) and phone clear button (United Kingdom and Europe).
12. CD Mix (where fitted) and preset and phone key pad 7.

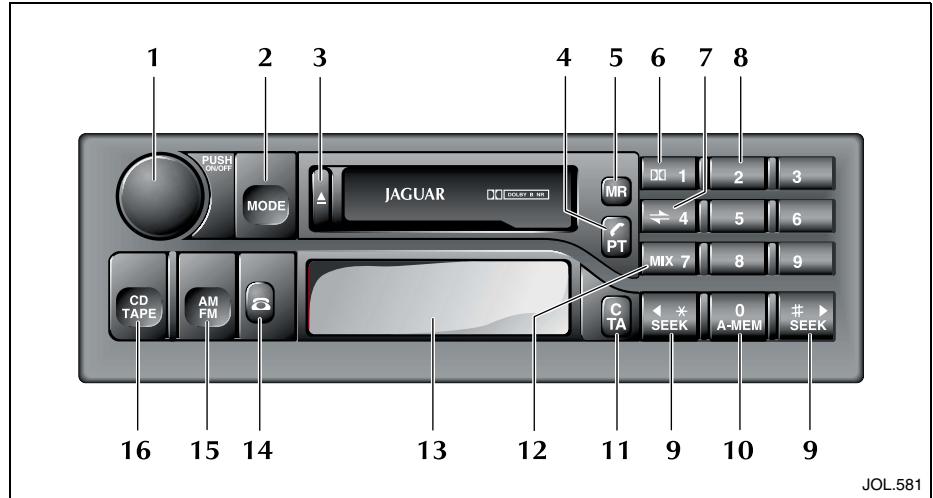

13. Display.
14. Phone mode button.
15. AM/FM band button
16. Cassette tape and CD player button (where fitted).

Steering wheel audio system controls (where fitted)

Four audio system control buttons are situated on the left-hand side of the steering wheel. These buttons override the functions of the similar buttons on the radio control panel.

- A. Press to increase volume.
- B. Press to decrease volume.
- C. Press and release to cycle through Radio FM, AM, Cassette or CDs.
Press and hold to enter phone mode.
- D. Press and release to seek to next preset radio station, or to next track on tape and CD.
Press and hold to cycle to the next radio station, or to the next CD, or to change side of tape.

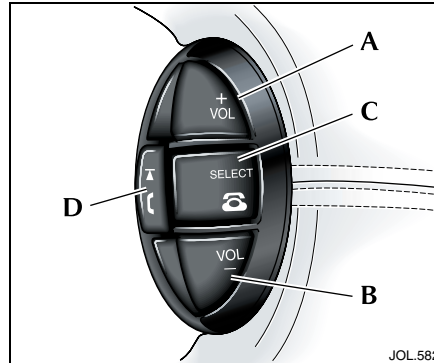

Sound system display

Example of radio display:



- TP Traffic Programme (Europe, United Kingdom and USA).
- TA Traffic announcement selected.
- ST Stereo.

1-4 Introduction and controls

Aerial operation

The aerial automatically rises when the radio is switched on and the ignition switch is in position **I** or **II**. The aerial will lower when the radio is switched off.

Note: The aerial will always be raised regardless of being in tape or CD modes, to enable RDS information to be received on the FM waveband.

Caution: Do not attempt to raise the aerial manually.

It is important to clean the radio aerial periodically to maintain smooth operation and good reception.

If your vehicle is fitted with a cellular telephone, you are advised to take the following precautions in areas where there is restricted overhead clearance such as an automatic car wash.

1. Switch the radio cassette and ignition OFF.
- or
2. Switch the radio cassette and cellular telephone OFF.

FM and AM reception

FM reception has the advantages of low noise, minimal distortion, wide dynamic range, extended frequency response, and is usually broadcast in stereo. However, as FM frequency waves are relatively short and travel in a straight line, they can sometimes be impeded by obstructions, adversely affecting reception in some parts of the country.

Whilst FM reception will generally provide better quality sound, AM reception or Medium Waveband (MW) and Long Waveband (LW) (United Kingdom and Europe) may be better in remote areas not covered by the shorter range FM transmitters.

When experiencing poor FM reception, background noise can be reduced by adjusting the Mode button into Treble adjustment position and reducing the treble setting.



ON/OFF and volume control

Press the knob to switch on the radio cassette and light up the display. Press the knob again to switch off. Turn the ON/OFF switch clockwise to increase volume and anti-clockwise to decrease volume.

Automatic volume control (AVC)

This is a feature which raises the volume of the radio to overcome road noise as the vehicle's speed increases. To switch AVC on or off, press the volume knob for more than two seconds. The current state will be displayed i.e. **AVC ON/AVC OFF**. To toggle ON/OFF momentarily, press the volume control knob again to change the state. The **AVC** level can be adjusted from **1** to **5** by turning the volume knob while in **AVC ON** mode. After five seconds of no action, the radio will return to normal radio mode.

When **AVC** is **ON**, it is possible to override the automatic mode by adjusting the volume manually.



Mode button

Press the mode button repeatedly to cycle through the various modes. Once a function has been selected, turn the volume control to adjust sound quality. After about five seconds the radio will return to normal volume control mode.

The modes are:

BASS Increase/decrease

TREBLE Increase/decrease

Note: A source tone memory automatically memorises bass and treble positions for radio, cassette tape and CD, allowing individual settings for each mode.

BALANCE Left to right

FADE Front to rear

NAV Set the relative levels of voice guidance volume to audio volume (voice guidance emphasis) – Only vehicles with Navigation Systems.

SUB-WOOFER Set sub-woofer level from -7 to +7 (premium systems only).

POSITION Using volume control, set speaker delays to optimise stereo sound for a selected seating position (premium systems only).

For example (see above right) sound can be optimised for the driver on the right by introducing a delay in speaker (A), effectively moving speaker (B) to the position shown, balancing the stereo effect.

Optimising sound (premium systems only)

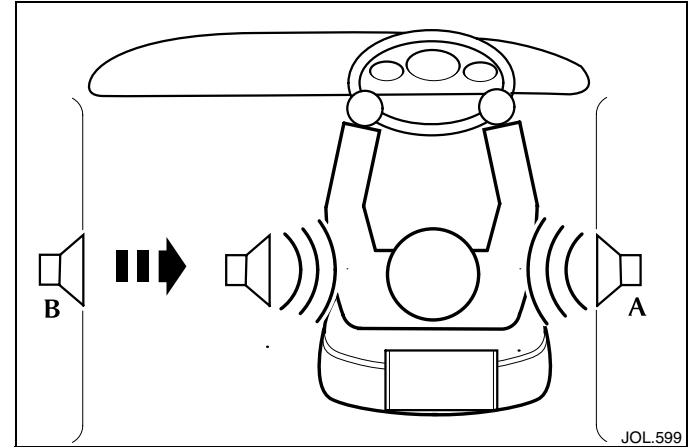

Sound can be optimised for the following seating positions:

- Front Left
- Front Right
- Centre (All)
- Rear

To select the seating position:

Press the mode switch until **POSITION** is displayed then turn the volume control to cycle through the available positions.

1-6 Introduction and controls

FADE Disable

On all convertible models fitted with the Premium Audio System, the FADE function is disabled at the factory.

Whilst Jaguar Audio Engineering recommends that FADE control is kept in this disabled condition, it can if desired, be re-enabled in the radio set-up mode as follows:

1. Simultaneously press the cassette eject and AM/FM buttons.
2. Pressing preset button **9** will then toggle between FADE ENABLE and FADE DISABLE as shown on the audio display panel.
3. To exit set-up mode, simultaneously press the cassette eject and AM/FM buttons. If the exit set-up procedure is not adopted within 15 seconds of selecting FADE enable or disable, the audio display will automatically clear and the system will return to the previous setting.

Note: If the audio system is set to FADE ENABLED and the sound is then faded to the rear, it should be noted that only low frequency sounds will be heard.



Preset buttons



WARNING:

Do not attempt to set the station presets while driving. Do this before starting a journey.

In each waveband, nine stations can be memorised in the bank of preset buttons marked **1** to **9**. After tuning to a station, hold the chosen preset button for at least two seconds. The unit will 'beep' to indicate that the station has been stored. The station can be recalled from this preset memory by pressing the button momentarily, for less than two seconds. The steering wheel preset selection button when pressed will cycle through the nine preset stations (see page 1-3).



Seek and manual tuning

This control has two functions: seek and manual tuning. Momentarily pressing either button will activate the radio in the seek mode, making the tuner search up or down the frequency range for the next available station.

Push and hold either button to tune the radio manually, the display counts up or down to the frequency required.

Incremental adjustment can be made by momentarily pressing the buttons until the required frequency is reached. (After a short period this will return to seek tuning if you momentarily press the button.)