

AIR BAGS

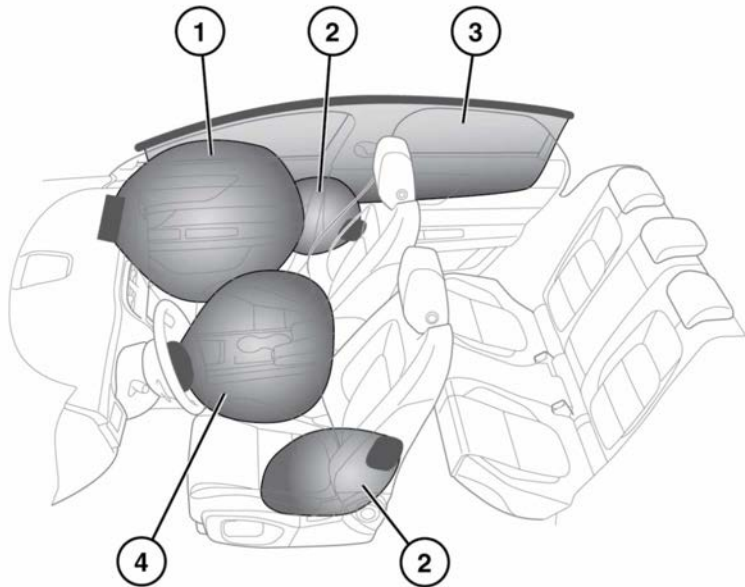

E174610

1. Front passenger's air bag.
2. Seat mounted side air bags.
3. Curtain air bag.
4. Driver's air bag.

Note: The general location of air bags fitted to the vehicle are marked by the words AIR BAG.

Always contact your Retailer/Authorized Repairer if:

- An air bag inflates.
- The front or sides of the vehicle are damaged.
- Any part of the air bag Supplementary Restraint System (SRS) shows signs of cracking or damage, including trim covering air bags.
- The amber air bag warning lamp illuminates.

⚠ DANGER

High speed impacts may cause serious injury or death irrespective of safety features fitted to a vehicle. Always drive with caution and consideration for the vehicle's characteristics, road and weather conditions, and do not exceed any speed limits in force.

⚠ DANGER

Seat belts should be worn at all times, by the driver and passengers in all seating positions. The air bag Supplementary Restraint System (SRS) cannot provide protection in some types of impact. Under these circumstances, the only protection will be provided by a correctly worn seat belt.

Air bags

AIR BAG OPERATION

National Highway Traffic Safety Administration (NHTSA) recommends a minimum distance of 10 in (25 cm) between an occupant's chest and the driver's air bag module.

Air bags provide additional protection in certain types of collision only - they do not replace the need to wear a seat belt. All occupants, in all seating positions, should always wear their seat belt, whether or not an air bag is present in that seating position.

WARNING

For the air bags to operate correctly the roof lining and door post trims must be in good condition, correctly fitted, and free from obstruction. Any damage, wear, or incorrect installation should be referred to your Retailer/Authorized Repairer as soon as possible for examination and repair.

WARNING

Air bags inflate at high speeds and can cause facial abrasions and other injuries. To minimize the risk of injury, make sure that all vehicle occupants wear correctly positioned seat belts, sit correctly in the seats, and position the seats as far back as practical.

WARNING

Air bag inflation takes place instantaneously and cannot protect against the effects of secondary impacts. Under these circumstances the only protection will be provided by a correctly worn seat belt.

Air bag deployment is dependent on the rate at which the passenger compartment changes velocity following the collision. Circumstances affecting different collisions (vehicle speed, angle of impact, type and size of object hit, etc.), vary considerably and will affect the rate of deceleration accordingly.

The air bags and Supplementary Restraint System (SRS) are not designed to operate as a result of:

- Rear impacts.
- Minor front impacts.
- Minor side impacts.
- Heavy braking.
- Driving over bumps and pot holes.

Therefore, it follows that considerable superficial damage to the vehicle can occur, without causing the air bags to deploy.

WARNING

The air bag SRS cannot provide protection in some types of impact. Under these circumstances the only protection will be provided by a correctly worn seat belt.

AIR BAG OBSTRUCTION

WARNING

Do not obstruct the operation of the air bags by placing any part of your person or any objects in contact with, or close to, an air bag module. If the air bag inflates, objects or any part of your person could interfere with the inflation of the air bag or be propelled inside the vehicle, causing injury to the occupants.

WARNING

Do not allow passengers to obstruct the operation of the air bags by placing feet, knees or any other part of the body, or any other objects in contact with, or in close proximity to, an air bag module.

Do not place objects between the air bag module and the seat occupant.

If the air bag inflates, objects or any part of their person could interfere with the inflation of the air bag, or be propelled inside the vehicle, causing injury to the occupants.

⚠ WARNING

Do not use non-approved seat covers or accessory seat covers that have not been designed for use with air bags. If in doubt, consult your Retailer/Authorized Repairer.

⚠ WARNING

Make sure a gap is maintained between the side of the vehicle, and the head and torso. This will enable unobstructed inflation of the curtain, and seat mounted side air bags.

⚠ WARNING

Do not attach or position items on, or close to the roof lining, front seatbacks, or to an air bag cover, which could interfere with the inflation of the air bag or be propelled inside the vehicle, causing injury to the occupants.

Note: Unauthorized modification of the vehicle or parts may invalidate the vehicle's warranty.

Air bag deployment is dependent on the rate at which the passenger compartment changes velocity following the collision. Circumstances affecting different collisions (vehicle speed, angle of impact, type and size of object hit, etc.), vary considerably and will affect the rate of deceleration accordingly.

Air bags cannot deploy correctly if they are obstructed. Examples of obstructions are:

- Any part of an occupant's body in contact with, or close to, an air bag cover.
- Objects placed on, or close to, an air bag cover.
- Clothing, sun screens, or other material hanging from grab handles.
- Clothing, cushions, or other material, covering seat-mounted air bags.
- Seat covers which are not approved by Jaguar, or specifically designed for use with seat-mounted air bags.

This list is not exhaustive and it remains the responsibility of the driver and passengers to make sure the air bags are not obstructed in any way.

FRONT AIR BAGS

The front passenger and driver air bags are able to deploy in two stages, depending on the severity of the frontal impact. In a severe impact, the air bags inflate fully to offer maximum protection. In a lesser impact, full deployment is not required, so the air bags are partially inflated.

SIDE AIR BAGS

These are designed to protect the thorax region of the torso and will deploy only in the event of a side impact and then, only on the side of the impact.

CURTAIN AIR BAGS

The curtain air bags are deployed in side impact and rollover events, providing greater protection from serious head injuries.

⚠ WARNING

For the curtain air bags to deploy correctly, the roof lining and A-post trim must be undamaged and fitted correctly. Any damage or suspect fitting should be referred to a Retailer/Authorized Repairer for examination.

Note: Curtain air bags will not inflate as a result of frontal or rear impacts alone.

AIR BAG DEPLOYMENT EFFECTS

WARNING

When an air bag inflates, a fine powder is released. This is normal and not an indication of a malfunction. The powder may cause irritation to the skin and should be thoroughly flushed from eyes and any cuts or abrasions. This powder can cause breathing difficulties for asthma sufferers or other people with respiratory problems. If this occurs, get out of the vehicle as soon as it is safe to do so or get fresh air by opening a window. If breathing problems persist, seek medical attention.

WARNING

Air bag deployment is accompanied by a very loud noise which may cause discomfort and temporary loss of hearing.

WARNING

After inflation, some air bag components will be very hot. Do not touch the air bag components until they have cooled sufficiently.

WARNING

After inflation, the front and seat-mounted side air bags deflate immediately. This provides a gradual cushioning effect for the occupants and also makes sure the driver's forward vision is not obscured.

AIR BAG WARNING LAMP

WARNING

Even with advanced air bags, children can be seriously injured or killed. Never place a child in any type of child restraint or booster seat in the front passenger seat. Children under the age of 13 should always ride in the back seat.

WARNING

The warning lamp indicates a potential fault with the vehicle's restraint system, which could result in serious injury or death in the event of a severe accident.

WARNING

If the warning lamp indicates that a fault is present in the system, do not use a child restraint on the front passenger seat.

The air bag warning lamp is displayed in the Instrument panel and will illuminate as a bulb check when the ignition is switched on. See **53, AIR BAG (AMBER)**.

If any of the following warning lamp conditions occur, the vehicle should be checked by your Retailer/Authorized Repairer immediately.

- The warning lamp fails to illuminate when the ignition is switched on.
- The warning lamp (following the bulb check) fails to extinguish within 8 seconds of the ignition being switched on.
- The warning lamp illuminates at any time other than the bulb check, when the ignition is on.

When the ignition is switched on, a diagnostic control unit monitors the readiness of the system's electrical circuits. The elements of the Supplementary Restraint System (SRS) being monitored include:

- SRS warning indicator.
- Rotary coupler.
- Air bag modules.
- Seat belt pre-tensioners (front and outboard rear seat belts).
- Front seat buckle switches.
- Front seat track position sensor.
- Air bag diagnostic control unit.

- Crash and rollover sensors.
- Air bag wiring harness.
- Seat occupancy sensor.
- Front passenger belt tension sensor.
- Air bag status indicator.

OCCUPANT SENSING

⚠ DANGER

Crash statistics show that children are safest when properly restrained in a child restraint system appropriate for their age and weight and secured in a rear seating position.

⚠ DANGER

Extreme hazard! Do not use a rearward facing child restraint on a seat protected by an air bag in front of it!

⚠ WARNING

For optimum safety, children under the age of 13 should travel in the rear of the vehicle at all times; front passenger seat travel is not recommended. An inflating air bag could cause serious injury or death to children riding in the front passenger seat.

⚠ WARNING

When checking the operational status of the front passenger air bag, make sure that the ignition is switched on.

The front passenger seat is fitted with an occupancy sensor system that determines if the seat is unoccupied, occupied by a person of low weight, a child seat or object, or is occupied by a heavier person or object.

The system consists of:

- A weight sensing pressure pad installed under the front passenger seat cushion. The sensor measures downward pressure/weight on the seat cushion.

- A seat belt tension sensor, integrated into the anchor point of the front passenger seat belt.
- A control unit installed under the front passenger seat.
- An air bag status indicator lamp, mounted on the overhead control panel (as illustrated) will display the operational status of the passenger air bag.

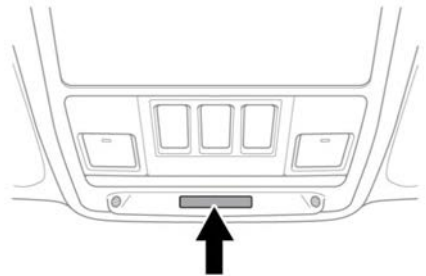

E165435

There are 3 operational states:

Occupancy status	Passenger air bag status	Status indicator display
Completely empty	Deactivated	PASSENGER AIR BAG OFF *
Child restraint or low weight occupant/object	Deactivated	PASSENGER AIR BAG OFF
Heavy occupant/object	Activated	ON PASSENGER AIR BAG **

* If the status lamp indicates that the air bag is off with a seated adult, contact your Retailer/ Authorized Repairer immediately.

** Displays for 60 seconds followed by no display.

Air bags

AIR BAG SERVICE INFORMATION

WARNING

Phone systems should be installed only by qualified persons familiar with the operation of, and requirements for, vehicles fitted with Supplementary Restraint System (SRS). If you are in any doubt, seek advice from your Retailer/Authorized Repairer.

WARNING

Do not attempt to service, repair, replace, modify, or tamper with, any part of the SRS. This includes wiring or components in the vicinity of SRS components. Doing so may cause the system to trigger, or render the system inoperative, either of which may result in serious injury or death.

WARNING

Do not use any electrical test equipment or devices in the vicinity of SRS components or wiring. Doing so may cause the system to trigger or render the system inoperative, either of which may result in serious injury or death.

For your safety, all of the following operations should only be carried out by a Jaguar Retailer/Authorized Repairer or suitably qualified person:

- Removal or repair of any wiring or component in the vicinity of any SRS components.
- Installation of electrical, or electronic, equipment and accessories.
- Modification to the front or sides of the vehicle exterior.
- Attachment of accessories to the front or sides of the vehicle.

Always contact your Retailer/Authorized Repairer if:

- An air bag inflates.
- The front or sides of the vehicle are damaged.
- Any part of the air bag SRS shows signs of cracking or damage, including trim covering air bags.

DISABILITY MODIFICATIONS

WARNING

Occupants, with disabilities that may require the vehicle to be modified, must contact a Jaguar Retailer/Authorized Repairer before any modifications are made. Failure to do so could result in the vehicle being rendered unsafe, potentially leading to personal injury. Modifications may adversely affect the vehicle which can lead to loss of control, resulting in a crash.

(USA only) If you are considering modifying your vehicle in any way to accommodate a disability, for example by altering or adapting the driver's or passenger's seat(s) or air bag system, please contact:

Jaguar Land Rover North America LLC
Customer Relationship Center
555 MacArthur Blvd
Mahwah
New Jersey 07430-2327
1-800-452-4827, option #9.