

## DOOR LOCKS AND RELEASE LEVERS

 While a door is open, the locking latch is exposed. Do not attempt to manually close the latch as it may also automatically 'soft close' and trap items or body parts.

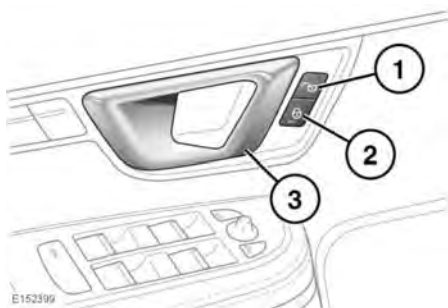

### 1. Unlock:

- Press any unlock button to unlock all of the doors. Alternatively, pull either front door release handle (3) once to unlock all of the doors.
- Pull either rear door release handle once to unlock the individual rear door.

**Note:** The unlock button is inhibited when the vehicle is locked with the Smart key.

### 2. Lock: With all the doors closed, press any lock button to lock all of the doors.

- ### 3. Door release handle: Pull to unlock and open the door. If the door is locked, pulling either front door handle once will unlock all of the doors. Pulling either rear door handle once will unlock the individual rear door.

**Note:** When activated, the Rear child security switch (located on the driver's door switch pack) will inhibit the rear door lock and unlock buttons and the rear door release handles. See 28, CHILD SAFETY LOCKS.

## SINGLE LOCKING

Press the lock button briefly. Single locking secures the vehicle and prevents the doors and luggage compartment being opened from outside of the vehicle. The doors can be unlocked and opened from inside the vehicle. The hazard warning lamps will flash once as confirmation.

## DOUBLE LOCKING

 **Never Double lock the vehicle with people, children or pets inside. In the event of an emergency they would be unable to escape, and the emergency services would be unable to release them quickly.**

**When the vehicle is Double locked the doors cannot be opened, either from inside or outside the vehicle.**

Press the lock button twice within 3 seconds. Double locking secures the vehicle and prevents the doors and luggage compartment from being unlocked or opened from inside or outside of the vehicle, except with the correct Smart key. The hazard warning lamps will flash twice (with a long second flash) and an audible warning will sound as confirmation.



The audible warning can be enabled/disabled by your Retailer/Authorised Repairer.

## LOCK CONFIRMATION

If you are uncertain whether the vehicle is locked and armed (either by Single or Double locking), press the lock button again. The hazard warning lights will flash to indicate and confirm the current lock status.

**Note:** If the vehicle is **not** already locked and armed, pressing the lock button will Single lock the vehicle. Press again to Double lock.

# Exiting the vehicle

## MISLOCK

If one of the doors, the bonnet or the luggage compartment are not shut fully when the vehicle is locked using the Smart key or by Keyless locking, the vehicle will not lock and 2 warning tones will sound. Check that all doors, the bonnet and the luggage compartment are closed properly and lock the vehicle again.

If one or more of the doors fails to lock properly when a lock attempt is made using the Smart key, 2 warning tones will sound and one or more of the doors may not be locked.

**Note:** *Operating the interior or exterior door handles, while attempting to unlock, lock, or change the child lock status of the vehicle (including Drive-away locking), may cause the security system to ignore any unlock, lock, or child lock requests.*

## GLOBAL CLOSING



**Make sure that no children, pets, or obstructions are in any open aperture before operating Global closing.**

Make sure that all of the doors are closed, then press and hold the lock button on the Smart key for 3 seconds. Alternatively, press and hold the lock button on the door handle. The vehicle will single lock and the alarm will be fully armed immediately. After 3 seconds, all of the windows will close.

**Note:** *If the button on the door handle is released before the windows have fully closed, the windows will stop closing.*

## KEYLESS LOCKING



Remove all Smart keys and emergency key blades from the vehicle when it is left unattended. This will help prevent the alarm being disarmed and therefore help prevent theft.



The Smart key may not be detected if it is placed within a metal container or if it is shielded by a device with a back-lit LCD screen, such as a smart phone, laptop (including when inside a laptop bag), game console etc.

The vehicle will not lock automatically.

To Single lock the vehicle, press the button on the door handle once. The hazard warning lamps will flash once as confirmation (in some markets, an audible warning will sound).

To Double lock the vehicle, press the button twice within 3 seconds. The hazard warning lamps will flash twice (with a long second flash). In some markets, a double audible warning will sound.

**Note:** *Keyless locking will only activate if all of the doors, bonnet and the luggage compartment are closed and the Smart key is outside the vehicle. If the above conditions are not met, 2 audible error warnings will sound.*

## FULL ALARM

To set full alarm protection, make sure that all the windows and the sunroof are closed. On vehicles fitted with Double locking, press the lock button twice within 3 seconds. The hazard warning lights will flash twice to confirm the alarm state and, in some markets, an audible tone will sound.

**Note:** *If the alarm is armed and a window or the sunroof are left open, the alarm may sound due to movement of air currents, detected by the intrusion sensors in the front interior light console.*

*The intrusion sensors can be temporarily disabled, for the next time the vehicle is locked, via the Vehicle Set-up area of the Instrument panel menu.*

## PERIMETER ALARM

To set Perimeter alarm protection, press the lock button. The hazard warning lamps will flash to confirm the alarm state.

## BATTERY-BACKED SOUNDER

In certain markets, a separate battery backed sounder is fitted. This device will sound the alarm if the vehicle battery or the alarm sounder is disconnected when the security system is armed.

## DEACTIVATING THE ALARM WHEN TRIGGERED

If the alarm has been triggered, it can be deactivated by any one of the following methods:

- Pressing the unlock button on the Smart key.
- Opening a door using Keyless entry.
- Pressing the START/STOP button with a valid Smart key present.

## TILT SENSOR

The Tilt sensor detects any change in the vehicle's angle to the ground. When the alarm is armed and the vehicle Double locked, any change in the vehicle's angle will activate the tilt alarm.

**Note:** *The tilt sensors can be temporarily disabled, for the next time the vehicle is locked, via the Vehicle Set-up area of the Instrument panel menu.*

## PASSIVE ARMING

This vehicle is fitted with a passive arming feature which can, if enabled, automatically arm the anti-theft system. Passive arming will automatically arm the perimeter alarm system 60 seconds after the driver's door is closed, provided all doors, bonnet and luggage compartment are closed, the ignition is switched off and there are no valid Smart keys inside the vehicle.

Passive arming will not lock the vehicle, although access to the luggage compartment via the interior or exterior release buttons will be prevented and the fuel filler flap will be locked.



Passive arming can be enabled/disabled by your Retailer/Authorised Repairer.

## AUTOMATIC RE-LOCKING AND RE-ARMING OF THE ALARM

Automatic relock and re-arm is a feature which, if enabled, automatically relocks the vehicle and arms the anti-theft system.

If the vehicle is in a locked and armed state and the remote unlock button is pressed, but none of the doors or the luggage compartment are opened within 40 seconds, the vehicle will automatically relock all the doors and the luggage compartment and will re-arm the alarm system.

**Note:** *Automatic relocking and arming will only relock and arm to the last locked and armed state.*



Automatic relocking and re-arming can be enabled/disabled by your Retailer/Authorised Repairer.

# Exiting the vehicle

## SENSOR FAULTS

If the security systems detect a fault with one of the security sensors, an error tone will sound from the alarm after the vehicle is unlocked and disarmed. If this condition occurs, please visit your Retailer/Authorised Repairer for rectification.

## EMERGENCY LOCKING

In the event of the battery discharging or a fault occurring with the Keyless locking system, the doors must be locked manually.

All unlocked doors, except the driver's door, should be locked using the following procedure. Finally the driver's door should be locked via the external door lock. See 4, **UNLOCKING THE VEHICLE**.

**Note:** Do not leave the emergency key blade in the vehicle at any point during the emergency locking procedure.

1. Open the door and locate the emergency lock access cover. There is a small chamfer on the back of the cover; using a finger nail, push up and away from the door to remove the cover.
2. Insert the emergency key blade firmly into the emergency lock until a click is heard. The emergency key blade can now be removed.

**Note:** The emergency key blade is stowed in the Smart key. See 4, **UNLOCKING THE VEHICLE**.

3. Replace the emergency lock access cover by fitting the lower clip first, then pushing the cover until it clicks into place.
4. Close the door and check to make sure the door is locked. Repeat the procedure for all other unlocked doors.

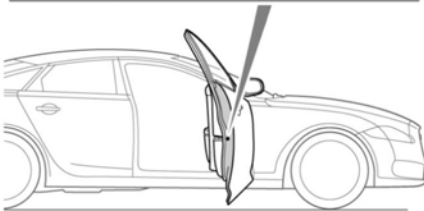
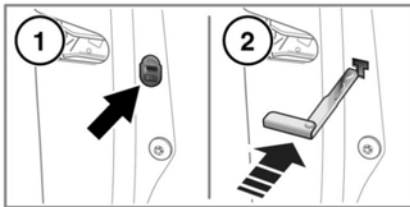

E164171