

EMERGENCY BRAKE ASSIST (EBA)

If the driver rapidly applies the brakes, EBA automatically boosts the braking force to its maximum, in order to bring the vehicle to a halt as quickly as possible.

EBA stops operating as soon as the brake pedal is released.

A fault with the EBA system is indicated by the brake warning lamp (see **45, BRAKE (RED)**) illuminating and a warning message is displayed in the Message center. Drive with care, avoiding heavy brake application and seek qualified assistance.

ELECTRONIC BRAKE-FORCE DISTRIBUTION (EBD)

EBD controls the balance of braking forces supplied to the front and rear wheels, in order to maintain maximum braking efficiency.

If the vehicle has a light load (only the driver in the vehicle, for example), EBD will reduce the braking force applied to the rear wheels. If the vehicle is heavily laden, EBD will allow greater braking force to the rear wheels.

A fault with the EBD system is indicated by the brake warning lamp (see **45, BRAKE (RED)**) illuminating and an associated warning message. Gently and safely stop the vehicle and seek qualified assistance.

ELECTRIC PARKING BRAKE (EPB)

⚠ WARNING

Do not rely on the Parking brake to hold the vehicle stationary if the brake warning lamp is illuminated or the EPB warning lamp is flashing. Seek qualified assistance urgently.

NOTICE

The Parking brakes operate on the rear wheels; therefore, secure parking of the vehicle is dependent on being on a hard and stable surface.

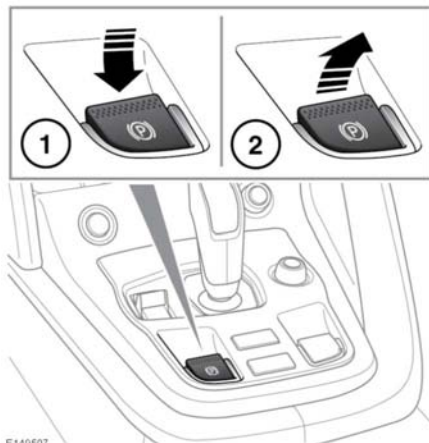

E149507

With the ignition switched on, press the brake pedal and press down on the EPB switch (1). This will release the Parking brake.

With the vehicle stationary, pull up the EPB switch (2). This will apply the Parking brake. A warning lamp (see **46, PARKING BRAKE (RED)**) illuminates to indicate that the Parking brake is applied.

If the EPB switch is operated when the vehicle's speed is less than 2 mph (3 km/h), the vehicle will be brought to an abrupt stop. The stop lamps will not be illuminated.

NOTICE

Driving the vehicle with the Parking brake applied, or repeated use of the Parking brake to slow the vehicle, may cause serious damage to the brake system.

Brakes

In an emergency, with the vehicle traveling at more than 2 mph (3 km/h), pulling on the EPB switch and holding gives a gradual reduction in the speed. The brake warning lamp will illuminate accompanied by a warning tone and a warning message in the Message center. The stop lamps will illuminate.

If the vehicle is stationary with the EPB applied and the transmission in **P**, pressing the accelerator pedal and selecting **D**, **N**, or **R** will release the EPB and allow the vehicle to move off. See **86, AUTOMATIC TRANSMISSION**.

Note: *Automatic release of the EPB is only possible when the driver's door is closed or the driver's seat belt is buckled.*

If the system detects a fault with the EPB, the amber brake warning lamp will illuminate accompanied by a message in the Message center.

If the system detects a fault while the EPB is operating, the red Parking brake warning lamp will flash, accompanied by a message in the Message center.

Note: *The red Parking brake warning lamp will continue to be illuminated for at least 10 seconds after the ignition has been turned off.*