

Convertible roof

CLOSING THE ROOF

With the ignition on, pull and hold the front of the switch. See **77, OPENING THE ROOF**. Do not release the switch until the convertible roof is fully latched closed and a confirmation message appears in the Message center.

Note: *If, at any period during the convertible roof closure sequence, the switch is released, all movement of the convertible roof will cease.*

MANUALLY CLOSING THE ROOF

In the event that the vehicle's systems will not close the convertible roof from the fully open position, then the manual closing procedure should be carried out.

⚠WARNING

Make sure that Park (P) is engaged, the Parking brake is applied, and the ignition is off.

Access the tools:

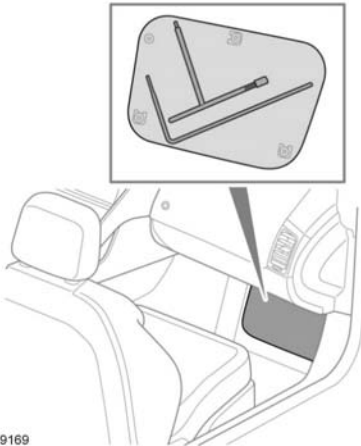

E149169

Remove the 2 tools from behind the passenger footwell fuse box cover. See **176, FUSE BOX LOCATIONS**.

Releasing and Closing the roof:

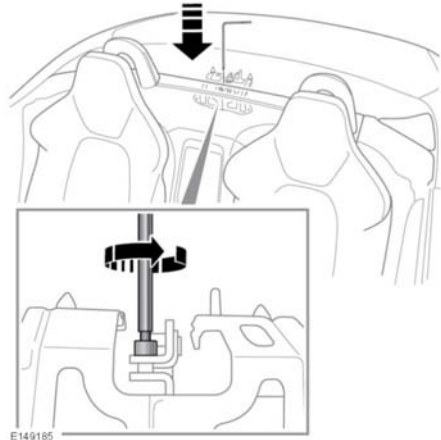

Using the allen key tool, rotate the release screw 7 turns counter-clockwise to release the down-lock mechanism.

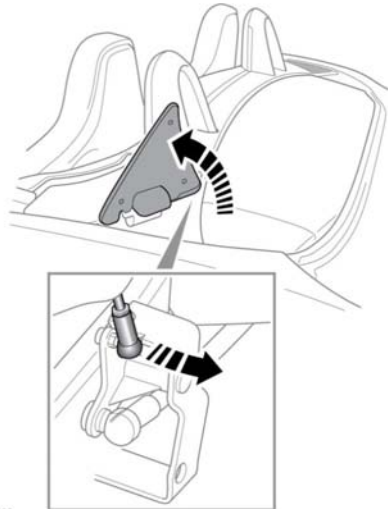

E151660

Lift the panel. A gradual increase of effort is required to reach the illustrated vertical position. Using the flat blade of the allen key tool, lightly pry off the control rod ball socket.

Repeat this procedure on the other side of the vehicle.

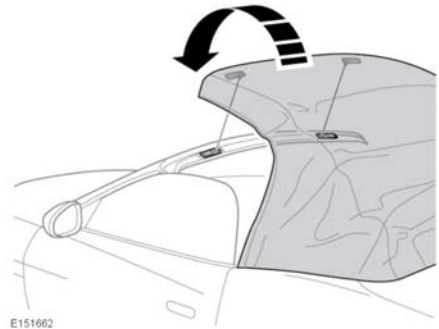
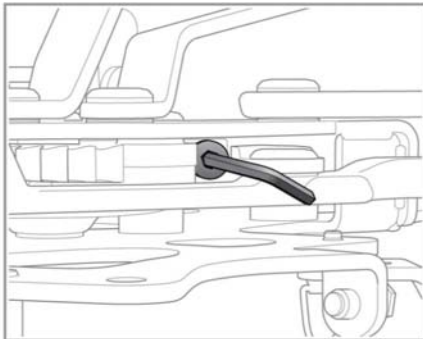

Carefully raise the roof to the closed position. An increase in effort is required to reach the fully closed position.

Note: Make sure the roof's front latch pins are aligned into the roof header latch locks.

To make sure that the convertible roof is fully closed, apply external downward pressure to each of the front latch pins, located at the front of the convertible roof.

Note: Take care not to damage the convertible roof or any other vehicle component.

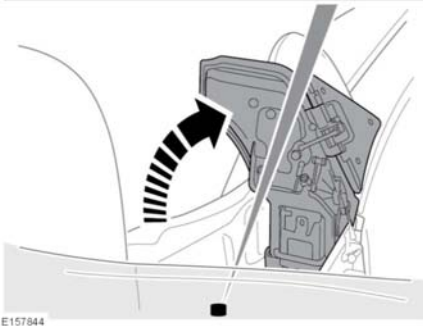

Lift the panel. With the allen key, unscrew and remove the bolt.

Repeat this procedure on the other side of the vehicle.

Convertible roof

Locking the roof:

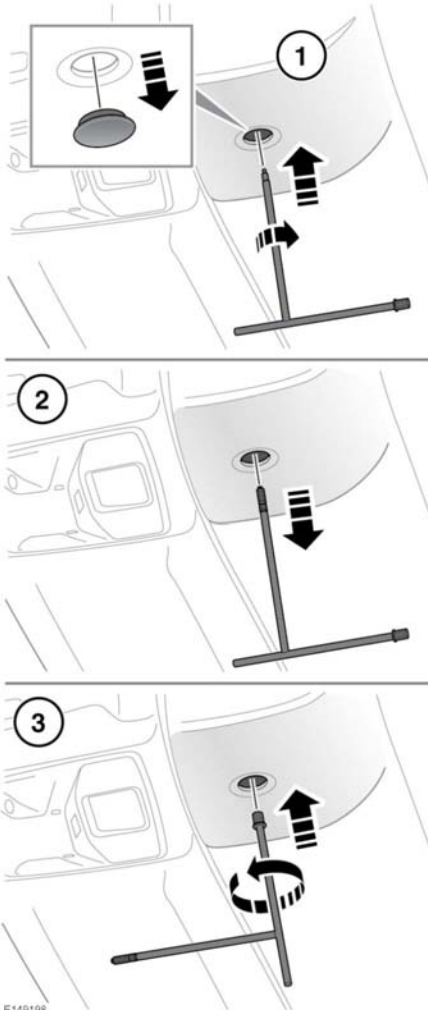

E149198

NOTICE

Care must be taken when screwing the tool into the motor shaft. Rotate clockwise until a resistance is felt and stop. Any attempt to over tighten may result in damage to the tooling and/or motor shaft.

1. Remove the access plug from the center of the roof header trim. Insert the screw thread end of the tool into the motor shaft. To fully engage, rotate clockwise until resistance is felt. It does not need to be tight.

2. Pull the tool to remove the motor shaft.

Note: A strong, positive downward pull is required.

Note: Remove the motor shaft from the tool and stow in the vehicle.

3. Apply external downward pressure to each of the front latch pins, located at the front of the convertible roof. Push the alternate, large serrated end of the tool into the motor and turn a complete revolution counter-clockwise. Remove the tool and replace the access plug.

Note: Take care not to damage the convertible roof or any other vehicle component.

4. Replace the tools and the passenger footwell fuse box cover.

Note: Do not attempt to operate the convertible roof until a repair has been carried out by a Dealer/Authorized Repairer.