

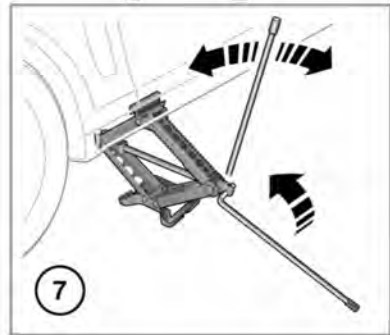

WHEEL CHANGING

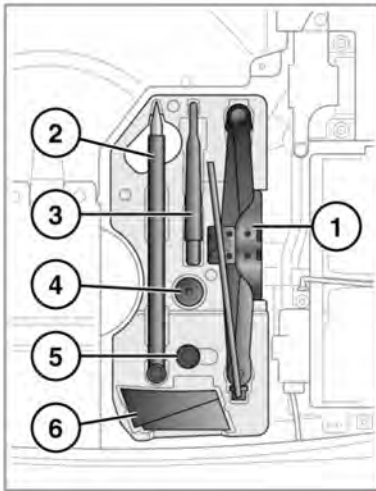



E152074

1. Jack assembly. Observe the instructions printed on the jack.
2. Wheel brace.
3. Towing eye.
4. Retaining nut.
5. Locking wheel nut adaptor.
6. Wheel chock.
7. There are 4 jacking points on the underside of the floor. 2 indented, triangular indicators are provided on each sill cover. These indicate the location for the jack.

 **Remove the spare wheel prior to jacking the vehicle, to avoid destabilising the vehicle when raised.**

See **201, IMPORTANT – USE OF SPARE TYRE** and **200, REMOVING THE SPARE WHEEL.**

Before raising the vehicle or changing a wheel, make sure that you read and comply with the following warnings:

-  **Do not attempt to raise the vehicle, unless the jack head is fully engaged in the jacking point. Only jack the vehicle using the approved jacking points.**
-  **The jack is designed for wheel changing only. Never work beneath the vehicle with the jack as the only means of support. Always use correctly rated vehicle support stands, before putting any part of your body beneath the vehicle.**
-  **Always use the complete jacking lever assembly throughout the tyre changing process, to minimise any chance of accidental injury.**