

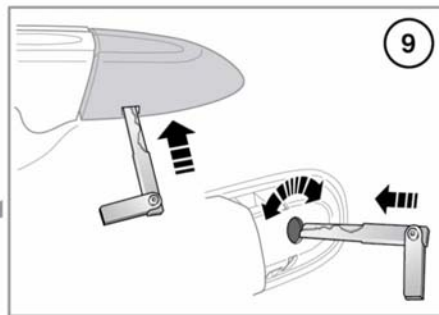

Entering the vehicle

UNLOCKING THE VEHICLE

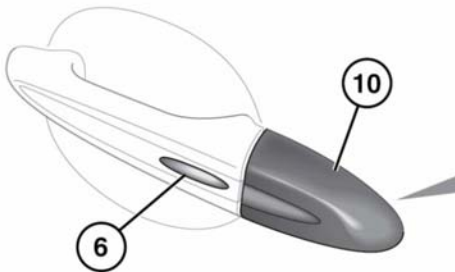
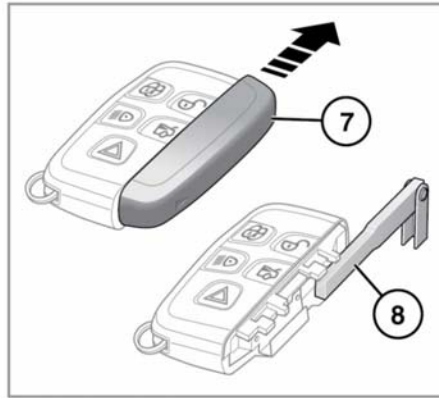
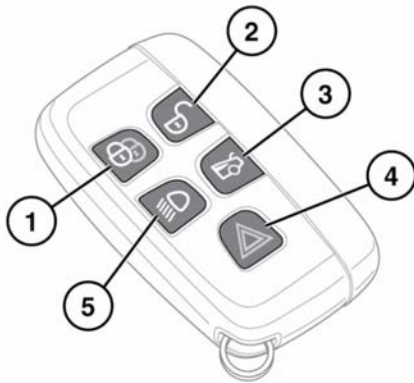

E152106

-  **To prevent accidental or unauthorised operation, never leave children or animals unattended in the vehicle. The vehicle can be operated when the Smart key is inside the vehicle.**
-  **While a door is open, the locking latch is exposed. Do not attempt to manually close the latch as it may also automatically 'soft close' and trap items or body parts.**

1. Lock: Press the lock button to secure the vehicle. The vehicle can be Single or Double locked. See 9, **SINGLE LOCKING** and 9, **DOUBLE LOCKING**.

2. Unlock: Your vehicle can be unlocked using either Single or Multi-point entry. When Single point entry is enabled, the first press unlocks the driver's door and enables the other doors to be opened from the inside. The hazard warning lamps will flash twice to indicate that the vehicle is unlocked and the alarm has been disarmed. A second press unlocks the passenger doors and the luggage compartment.

If Multi-point entry is enabled, press briefly to unlock all of the doors and the luggage compartment and to disarm the alarm. The hazard warning lamps will flash twice to indicate that the vehicle is unlocked and the alarm has been disarmed.

To change from Single to Multi-point entry (or vice versa), press both the lock and unlock buttons simultaneously for 3 seconds. The hazard warning lamps will flash twice to confirm the change.

The change can also be achieved using the Instrument panel menu.

3. Press to open the luggage compartment. The vehicle security system will remain active for the period that the luggage compartment is open but the intrusion and inclination sensing systems will be inhibited. Door and bonnet security will remain active.
The security system will re-arm to its previous state when the luggage compartment is closed.
4. Panic alarm: Press and hold for 3 seconds, or press 3 times within 3 seconds, to activate the horn, siren and hazard lamps. After 5 seconds, the alarm can be cancelled by pressing the panic alarm button for 3 seconds or by pressing the button 3 times within 3 seconds.
The emergency alarm will also be cancelled if the vehicle detects a valid Smart key when the START/STOP button is pressed.
5. Press to switch on the approach illumination for up to 120 seconds. The illumination time is set using the exit delay switch. Pressing the button again or operating the starter button will turn the approach lamps off.
6. Keyless locking button. See **10, KEYLESS LOCKING**.

7. Emergency key cover: Slide and remove the cover to expose the emergency key.
8. Emergency key: Slide the key to remove and then unfold the handle.
9. To unlock or lock the door in an emergency (if the Smart key or Keyless entry fail to operate):

- Insert the emergency key blade into the slot in the door lock cover.
- Carefully lift the key blade to lever the cover off the retaining clips.
- Insert the key blade into the exposed lock to operate.

To lock: Make sure that all of the doors are closed, then turn the key blade towards the front of the vehicle and release. This will lock all of doors but will not arm the alarm.

To unlock: Turn the key blade towards the rear of the vehicle and release to unlock the door. If the security system is disarmed, all the doors and the luggage compartment will be unlocked.

Note: If the vehicle is unlocked using the emergency key blade with the security system armed, the alarm will sound when a door is unlocked. To deactivate the alarm, press the unlock button on the Smart key or press the engine START/STOP button with the Smart key inside the vehicle.

10. To replace the door lock cover:
 - Align the cover to engage the top 2 clips.
 - Push the bottom of the cover to engage the lower clip.

Entering the vehicle

KEYLESS ENTRY



Any person fitted with an implanted medical device should make sure that the device is kept at a distance of at least 22 cm (8.7 inches) away from any transmitter mounted in the vehicle. This is to avoid any possibility of interference between the system and device.

For information concerning the locations of the security system transmitters, see 210, REMOTE KEY FOB TRANSMITTER LOCATIONS.



If a Smart key is lost, a replacement can be obtained and reprogrammed to the vehicle by a Dealer/Authorised Repairer. Notify a Dealer/Authorised Repairer as soon as a Smart key is lost or stolen and have the remaining Smart key(s) reprogrammed.

Keyless entry allows the vehicle to be unlocked and disarmed by simply operating the door handle, provided the Smart key is within 1 metre (3 feet).

The Smart key needs only to be on the driver's person; it does not need to be exposed or handled. However, the Smart key may not be detected if it is placed within a metal container or is shielded by a device with a back-lit LCD screen, such as a smart phone, laptop (including when inside a laptop bag), games console etc. Keep the Smart key clear of such devices when attempting Keyless entry or Keyless starting.

Note: *Keyless entry will unlock the vehicle in accordance with the current security setting (Single-point or Multi-point entry). However, if Single-point entry is the current setting and a door other than the driver's door is opened first, all doors will unlock.*

When all open doors have been closed, the system will search the vehicle interior for a valid Smart key. If one is not detected, **SMART KEY NOT FOUND, PLACE AS SHOWN** will be displayed in the message centre. Find the Smart key and place it against the fascia, below the auxiliary switch pack, see **79, KEYLESS START BACKUP**.

The security system fitted to your vehicle is Thatcham category 1 approved, and meets EU regulations 97/116 and EU directive 95/56 EC.

GLOBAL OPENING

Press and hold the unlock button for 3 seconds. The vehicle will unlock and the alarm will be disarmed immediately. After 3 seconds, all of the windows will open. This feature can be enabled/disabled via the Instrument panel menu.

To stop the windows from opening/closing during the global opening/closing operation, press any of the buttons on the Smart key or operate the driver's window switch. To stop a particular window from opening, operate the relevant window switch.

For Global closing, see **10, GLOBAL CLOSING**.

DRIVE-AWAY LOCKING

Locks all of the doors when the vehicle exceeds 8 km/h (5 mph). Use of the central locking/unlocking buttons (see **238, DRIVER CONTROLS**) will override the Drive-away locking feature for the rest of a journey.

If a door is individually unlocked and opened, all of the doors will relock when the open door is subsequently closed.

Note: *Drive-away locking can be enabled/disabled via the Vehicle Set-up area of the instrument panel menu.*

CONVENIENCE MODE

When the door is opened using either the Smart key or Keyless entry, the vehicle's electrical system initiates the Convenience mode. The following systems become functional:

- Driver position memory.
- Seat and steering column adjustment.
- Interior and exterior lighting.
- Message centre.
- Auxiliary power socket.

STEERING COLUMN LOCK

Your vehicle is fitted with an electronic steering column lock. The column unlocks when a Smart key is detected inside the vehicle.

If any malfunction of the steering column lock occurs, **STEERING COLUMN LOCKED** will be displayed in the message centre. If this occurs:

1. Lock and then unlock the vehicle using the Smart key.
2. Try again to unlock the steering column lock, by turning the steering wheel gently to the left and right while locking and then unlocking the vehicle using the Smart key.
3. If the problem persists, seek qualified assistance immediately.

REMOTE KEY FOB CARE



To prevent accidental operation, which may result in an injury, never leave the Smart key in the vehicle if children or animals are also left in the vehicle.



Do not expose to extremes of heat, dust, humidity or allow contact with fluids. Do not leave the transmitter exposed to direct sunlight.

The emergency key number is recorded on an attached label. Peel off the label and attach it to the designated area on the Security Card, supplied in the literature pack. Keep the Security Card safe, but not in the vehicle.

The operational range of the Smart key will vary considerably depending on atmospheric conditions and interference from other transmitting devices.

Note: The radio frequency used by the Smart key may be used by other devices (e.g. medical equipment). This may prevent the Smart key from operating correctly.

REMOTE KEY FOB BATTERY REPLACEMENT

When the battery needs replacing, there will be a significant decrease in the effective range and the message **SMART KEY BATTERY LOW** is displayed in the Message centre.

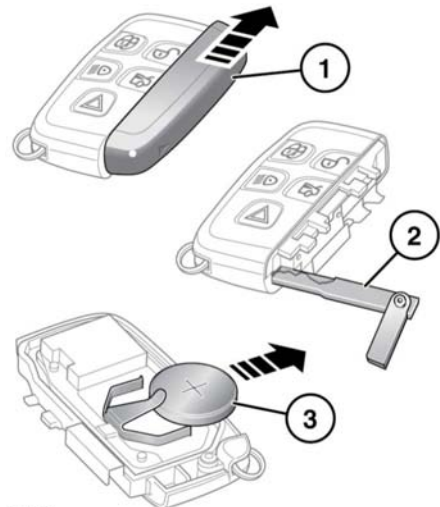

E150890

Entering the vehicle

To replace the battery:

1. Slide the cover in the direction of the arrow until a click is heard. Remove the cover.
2. Use the emergency key blade to separate the Smart key body.
3. Fit a new and unused CR2032 type battery (available from a Dealer/Authorised Repairer), with the positive (+) side upwards.

Note: Handle a new battery with the outer edge. Avoid touching the top and bottom faces of the new battery, as moisture/oil from your fingers can reduce battery life and corrode the contacts. If skin contact is made clean with a lint free cloth.

Note: If the low battery warning does not extinguish this indicates that the replacement battery is not in a new and unused condition.

Refit the parts in the reverse order, ensuring that they click securely into place.



Battery disposal: Used batteries must be disposed of correctly, as they contain harmful substances. Seek advice on disposal from a Dealer/Authorised Repairer and/or a local authority.