



Tyre pressure monitoring system (TPMS)

TYRE PRESSURE MONITORING SYSTEM

 **TPMS provides a low pressure warning and does not re-inflate your tyres. Tyre pressures should be checked regularly using an accurate pressure gauge when cold.**

 **TPMS can NOT register damage to a tyre. Regularly check the condition of your tyres.**

 When inflating tyres, care should be taken to avoid bending or damaging the TPMS valves. Always make sure of correct alignment of the inflation head to the valve stem.

Note: Different types of tyre may affect TPMS performance. Always replace tyres in accordance with recommendations.

TPMS constantly monitors the tyre pressure in each wheel except for the temporary use spare tyre (when fitted) which is not monitored.

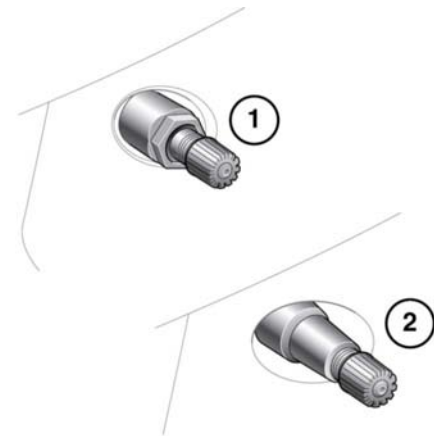

E132513

Wheels fitted with TPMS can be visually identified by the external metal lock nut and valve (1). All Jaguar non-TPMS wheels have a rubber valve fitted (2).

Tyre pressures should be checked regularly when cold, and adjusted as necessary. The presence of TPMS does not remove the need to do this to ensure vehicle safety.

The tyre pressure warning lamp (see 41, **TYRE PRESSURE MONITORING SYSTEM (YELLOW)**) illuminates when one or more of the tyres are significantly under-inflated. Stop and check the tyres as soon as possible and inflate them to the recommended pressure for the vehicle loading condition.

TEMPORARY USE SPARE WHEEL AND TYRE CHANGE

If the temporary use spare wheel is fitted, the system will automatically recognise the change in wheel positions. After approximately 10 minutes of driving above 25 km/h (18 mph), the message **FRONT[REAR] RIGHT[LEFT] TYRE PRESSURE NOT MONITORED** will be displayed, accompanied by illumination of the warning lamp.

The warning lamp will first flash and then illuminate continuously. Extended use of the temporary use spare wheel will trigger the message **TYRE PRESSURE MONITORING SYSTEM FAULT**.

This TPMS display sequence will be activated at every ignition cycle until the temporary spare wheel is replaced by a full-size road wheel with a TPMS sensor fitted.

Note: If in use, always replace the temporary spare wheel before having a TPMS fault investigated.