

The bulb holder is a plastic unit that incorporates the bulb. No tools are required but a torch may be of use.

1. At the rear of the lamp unit, turn the bulb holder a small amount counter-clockwise, until resistance is felt then lightly pull to release. Lower the bulb holder as far as the attached wiring will allow.

Note: Prior to and during removal, note the bulb housing orientation to aid installation.

2. Remove the bulb from the holder by lightly pressing and turn a small amount counter-clockwise, until resistance is felt, then lightly pull.

Note: Note the orientation of the bulb alignment lugs during removal.

Reverse the removal process to install a new bulb and refit the bulb holder to the lamp unit.

See **180, BULB SPECIFICATION** for the replacement bulb specification list.

REVERSE LAMP BULB REPLACEMENT

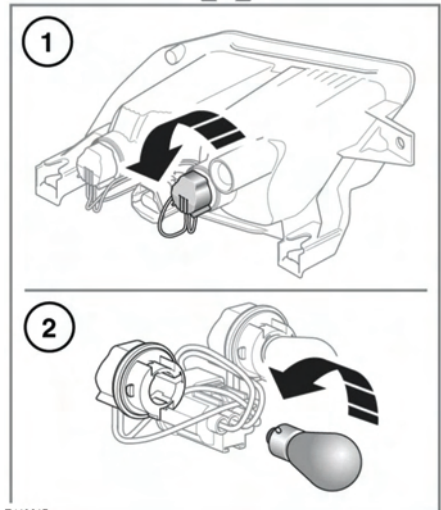
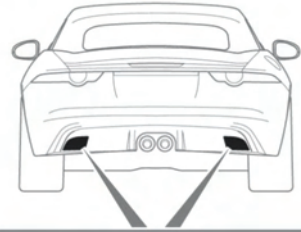

E149947

Access to the 3.0L vehicle's reverse lamp housing is from underneath the rear bumper.

Note: The 5.0L vehicle has a light emitting diode (LED) bulb in the rear fog lamp. Removal of this lamp unit should only be attempted by a qualified technician. If in doubt, consult a Dealer/Authorised Repairer.