

# Convertible roof

## OPENING THE CONVERTIBLE ROOF

### **⚠ WARNING**

Before opening or closing the convertible top, ensure that no occupants have any part of their body in a position where it could be trapped.

### **⚠ WARNING**

Do not attach or position items on, or close to, the Rollover Protection Device covers or tonneau panel (convertible roof cover panel) which could interfere with the operation of the Rollover Protection Devices or be propelled inside the vehicle causing injury to the occupants.

### **NOTICE**

Do not attempt to operate the convertible top at temperatures below 5°F (-15°C). This may cause damage to the fabric.

### **NOTICE**

If the convertible top is operated above 15 mph (24 km/h), there is a risk of damage to the convertible roof.

### **NOTICE**

Do not attempt to open the convertible roof manually, as damage to the linkage mechanism may occur.

**Note:** The convertible roof will not operate unless the luggage separator is correctly located in the deployed position in the luggage compartment (see **69, LUGGAGE SEPARATOR**) and that the luggage compartment lid is firmly closed.

**Note:** Do not press the engine START/STOP button during the opening or closing of the convertible roof. The convertible top will stop opening/closing and will have to be manually re-set, see **71, CONVERTIBLE ROOF MANUAL RE-SET**.

**Note:** Check that there is nothing in the rear area which could interfere with the convertible roof when folding down, e.g. ensure that the battery cover trim is fitted and secure.

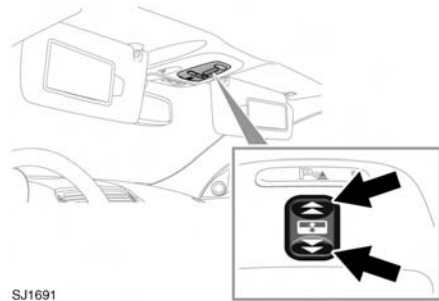

The power operated convertible roof and rear quarter windows, are controlled by the switch located on the overhead console. The ignition system must be on. The roof will latch and unlatch automatically.

The top can be operated at speeds below 15 mph (24 km/h). However, for safety it should not be opened or closed when the vehicle is being driven.

1. Ensure that the ignition is on.
2. Ensure that the luggage separator in the luggage compartment is in the fully deployed position. If it is not positioned correctly the proximity switches will not operate and the convertible roof will not open.
3. Press and hold the rear of the overhead console switch (do not release the switch until the roof is fully open).

**Note:** If the convertible roof ceases to operate while opening, see **71, CONVERTIBLE ROOF MANUAL RE-SET**.

4. The rear quarter windows open, an audible warning sounds and the top unlatches and starts to move. The tonneau panel (convertible roof cover panel) opens (the front windows will fully open. The door window switch will require to be pressed to close the windows).
5. When the roof is fully open, the audible warning sounds again. The tonneau panel is fully automated and encloses the convertible top in the stowed position.
6. Release the overhead console switch.

**Note:** *If at any period during the convertible top opening sequence the switch is released, all movement of the convertible top will cease.*

## CLOSING THE CONVERTIBLE ROOF

With the ignition on:

- Press and hold the front of the overhead console switch, see **68, OPENING THE CONVERTIBLE ROOF**. Do not release the switch until the convertible roof is fully closed and latched and, if required, the rear quarter windows and front door windows are fully closed.
- If the front windows are in any other position than fully down, they will retract to the fully down position on pressing the closure switch.
- When the roof is fully closed and latched, the rear quarter windows will close, followed by the front door windows returning to the fully closed position.

**Note:** *If at any period during the convertible top closure sequence, the switch is released, all movement of the convertible top will cease.*

## LUGGAGE SEPARATOR

### **NOTICE**

*Luggage items should not be placed forward of or on top of the luggage separator, as this could cause damage.*

### **NOTICE**

*Do not place large objects underneath the luggage separator partition when deployed. This may damage the convertible roof.*

A luggage separator is located in the luggage compartment, to prevent items from moving into the area where the convertible roof is stowed.

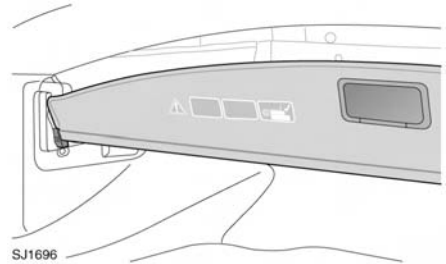

When the convertible roof is closed, the normal position for the luggage separator is in the retracted position, with the partition positioned vertically (as shown).

**To deploy the luggage separator:**

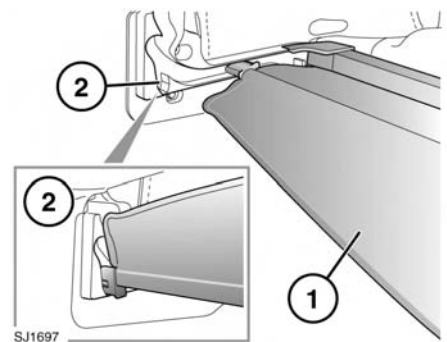

# Convertible roof

If the luggage separator is in the stowed position:

- Using the handle, slide the luggage separator (1) towards the rear of the vehicle until it stops.
- Lift the separator to the vertical position and drop into the lug slots (2) on both sides of the luggage separator.

**To remove the luggage separator:**

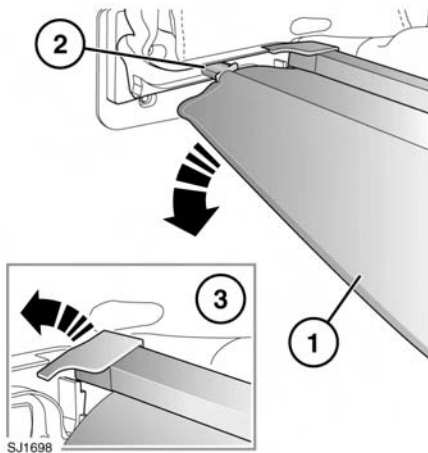

With the luggage separator in the stowed position:

- Using the handle, slide the luggage separator (1) towards the rear of the vehicle.
- Disengage the lugs (2) by twisting the luggage separator.
- Holding the center of the main body of the luggage separator, rotate upwards (3), disengaging the main body of the luggage separator from the support brackets.
- Remove the luggage separator.

**To install the luggage separator:**

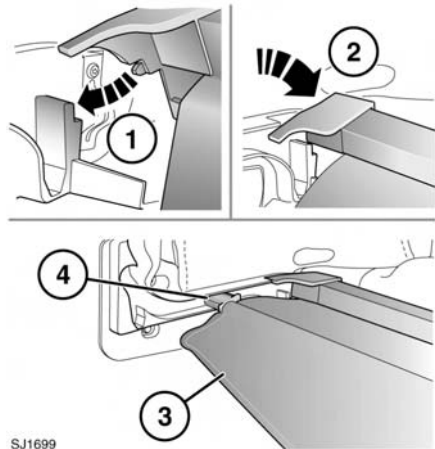

With the luggage separator slightly extracted:

- Position the luggage separator over the support brackets.
- On both sides of the main body of the separator, locate the catches into the slots in the support bracket (1).
- Rotate the main body (2) until it sits down into the support bracket (checking that it is correctly seated on both sides).
- Twist the luggage separator (3) and locate the lugs into the sliders (4).

## CONVERTIBLE ROOF MANUAL RE-SET

### NOTICE

It is advisable that two persons carry out the following procedure.

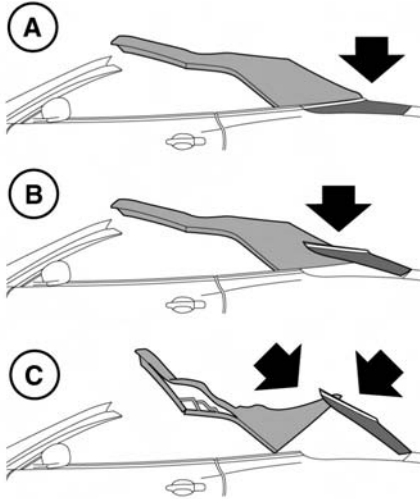

SJ1693

If the convertible roof ceases to operate while opening, it can stop in any of the positions shown (A, B or C). The convertible roof will require a manual re-set.

### To manually re-set the convertible roof:

Ensure that the engine is not running and that the ignition is off.

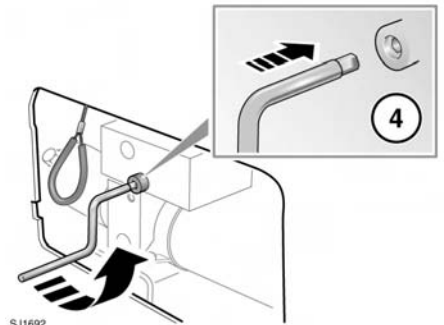
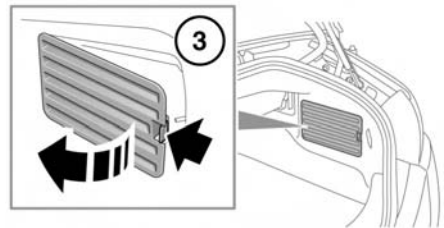
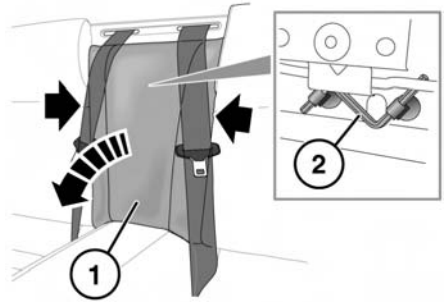

SJ1692

- Remove the rear seat center section (1) by grasping the sides of the section and pulling sharply. Locate and remove the allen key (2).
- From inside the luggage compartment, remove the vent screen (3) to access the convertible roof operating pump.
- Insert the allen key into the pump (4) and rotate counter-clockwise (approximately one turn).

# Convertible roof

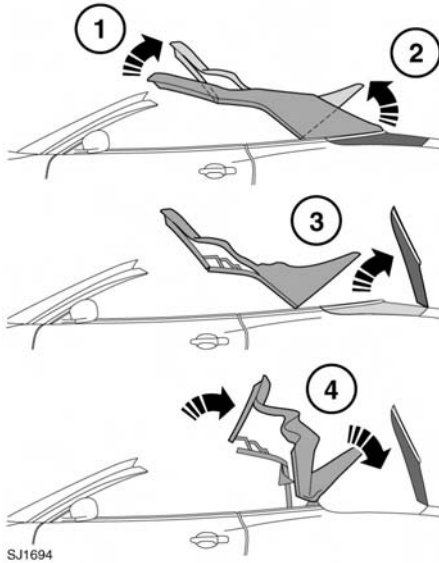

When the convertible roof has been re-set:

- Turn the allen key clockwise approximately one turn, remove the allen key and refit the vent screen.
- Stow the allen key and refit the rear seat center section.
- Close the luggage compartment lid.
- Start the engine, press and hold the front of the convertible roof switch until the convertible roof is closed and latched.

If the convertible roof stops operating in position **A**:

- To release the tension in the convertible roof, lift the front (1) and rear (2) of the convertible roof.
- Lift the tonneau panel into the fully open position (3) and support.
- Fold the convertible roof into the fully stowed position (4).
- Rest the tonneau panel in the closed position.

If the convertible roof stops operating in position **B** or **C**:

- Lift the tonneau panel into the fully open position and support.
- Fold the convertible roof into the fully stowed position (4).
- Rest the tonneau panel in the closed position.

## MANUAL CLOSURE OF THE CONVERTIBLE ROOF

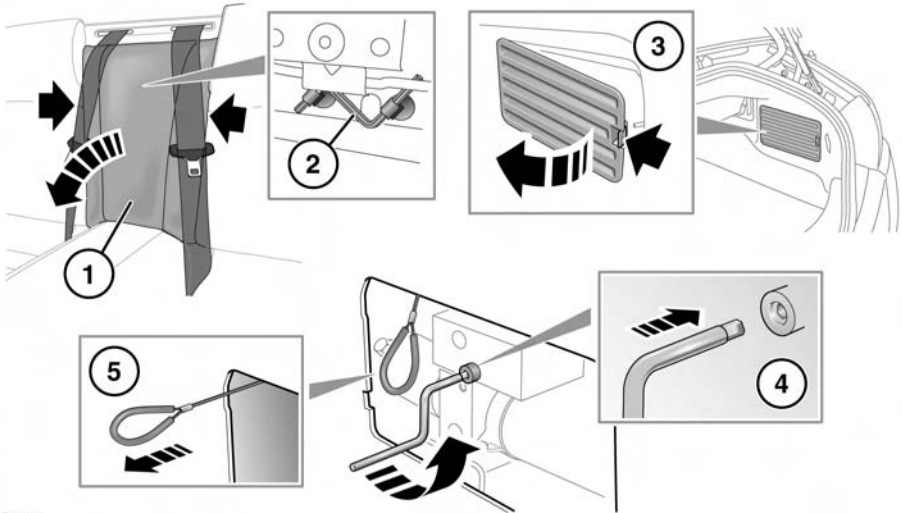

SJ1695

### To manually close the convertible roof:

- Remove the rear seat center section (1) by grasping the sides of the section and pulling sharply. Locate and remove the allen key (2).
- From inside the luggage compartment, remove the vent screen (3) to access the convertible roof operating pump.
- Insert the allen key into the pump (4) and rotate counter-clockwise (approximately one turn).
- Pull the tonneau panel release cable until fully extended. Close the luggage compartment lid.

**Note:** The release cable could be located behind the pump assembly.

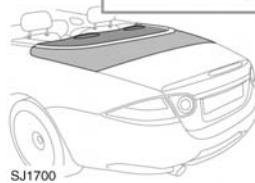
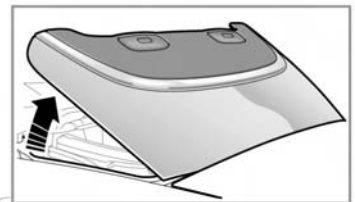

SJ1700

- Fully open the tonneau panel. It will self-support when fully open.

# Convertible roof

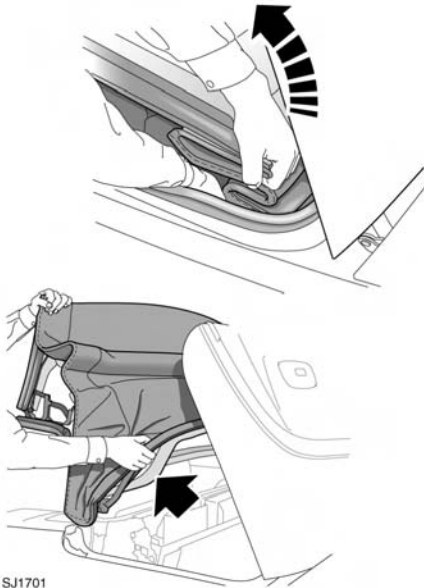

- From the left-hand side of the vehicle, place your right hand down the side of the folded convertible roof. Ensure that the bottom of the convertible roof, which includes the tension bow (arrowed), is securely held. Securely hold the convertible roof header assembly with your left hand. With both hands pull the whole of the convertible roof up and forward making sure that the tension bow is fully raised.

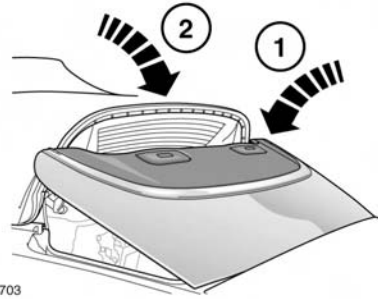

- Supporting the tension bow, lower the tonneau panel (1). Then lower the tension bow (2) onto the tonneau panel.

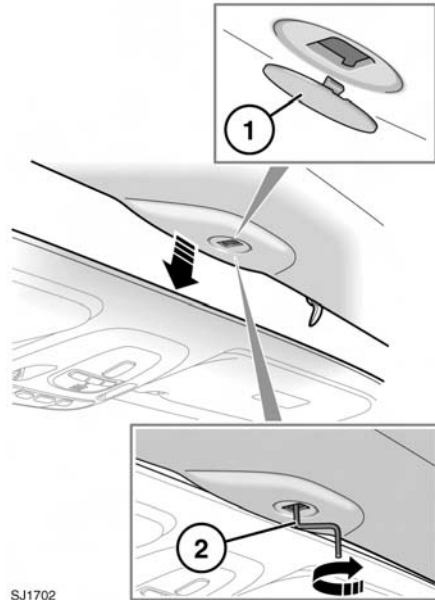

- Remove the plug from the convertible roof header trim (1).
- Pull down and support the front header. Insert the allen key into the header panel key slot (2) and turn clockwise until the top is securely latched and resistance is felt.

- Remove the allen key and replace the plug in the header trim.

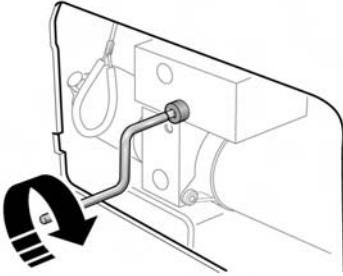

- In the luggage compartment, insert the allen key into the pump, turn clockwise approximately one turn.
- Remove the allen key and refit the vent screen. Stow the allen key and refit the rear seat center section.