

# Voice control

## OPERATION

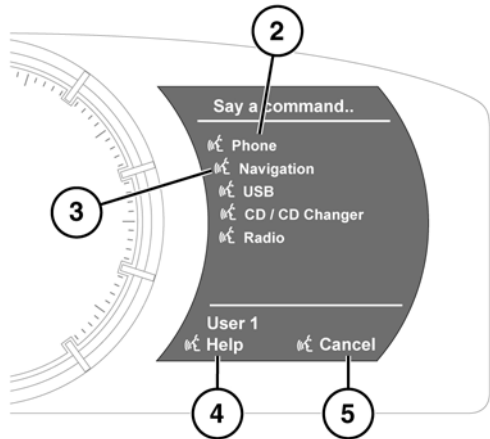

SJ1086

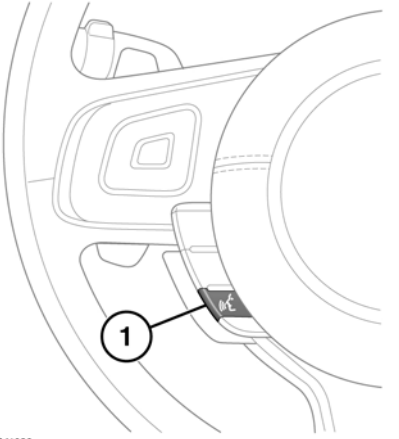

**WARNING: Do not allow the telephone, navigation or touch screen systems to distract the driver while the vehicle is moving. Driver distraction can lead to accidents causing serious injury or death.**

1. Voice button: Press briefly to start a voice session. Press and hold to cancel a voice session.

**Note:** Briefly press the Voice button during a voice session, to interrupt audible feedback. Wait for the tone to sound before giving the next command.

2. Command list. Provides feedback and available commands at each stage of the voice session.
3. Voice symbol: Indicates that a command is available. Wait for the symbol to appear (a tone will also sound) before using the command.
4. When displayed, say **Help** to get assistance during a voice session.

5. When displayed, say **Cancel** to cancel the current voice session.

- Briefly press the Voice button to start a voice session.
- Wait for the command list to appear in the instrument panel. When the system is ready, a tone sounds and the voice symbols appear next to the commands.
- Say an available command.

**Note:** As the commands are listed before the system is ready to listen, it is important to wait for the voice symbol to appear alongside the relevant command, before using the command.

- Wait for the list to update with any feedback and available commands for the next stage of the session. Wait for the tone to sound.
- Say the next command.
- Repeat this procedure until the chosen task is accomplished.

## VOICE TUTORIAL

To listen to a tutorial detailing the operation of the Voice system:

- Briefly press the Voice button to start a voice session.
- Wait for the tone to sound, then say **Voice tutorial**.

The voice tutorial can be cancelled at any time by selecting **Cancel** on the on-screen pop-up or by pressing and holding the Voice button.

## VOICE TRAINING

This is a feature designed to enable the system to better recognize the vocal characteristics of a user, once the training has been completed.

To carry out Voice training:

- Select **Setup** from the Home menu.
- Select **Voice** and from the Setup menu.
- Select **Voice training** from the Voice settings menu.
- Select **User 1** or **User 2**, to start the training.
- Follow the on-screen and audible instructions.

The training session can be cancelled at any time by selecting **Cancel** from the on-screen pop-up or by pressing and holding the Voice button.

## VOICE SESSION INTERRUPTIONS

Certain conditions will cause the current voice session to be cancelled, as follows:

- If a high priority warning appears in the message center.
- If there is no user input for a sustained length of time.

After four seconds, you may press the Voice button to start a new voice session.

## VOICETAGS

Voicetags enable the user to personalize the Voice system so that a single name can be used to call-up a navigation destination, telephone number or radio channel.

To add a Voicetag:

- Select **Setup** from the Home menu.
- Select **Voice** from the Setup menu.
- Select **Voicetags** from the Voice settings menu.
- Select the system which the Voicetag is to activate (**Phone**, **Navigation** or **Radio**).

Follow the on-screen and audible instructions.

## NAVIGATION POI VOICE COMMANDS

To request the display of POI (Point Of Interest) identifiers on the navigation display, say the command **Navigation**, followed by the name of the desired POI category from the list below (e.g. **Navigation Parking**).

- **Navigation (Gas Station | Gas)**
- **Navigation Parking**
- **Navigation Jaguar Dealer**
- **Navigation Hospital**
- **Navigation Police Station**
- **Navigation Golf Course**
- **Navigation Tourist Information**
- **Navigation (Restaurant | I'm Hungry)**
- **Navigation Shopping Mall**
- **Navigation Hotel**
- **Navigation Rest Area**
- **Navigation City Center**
- **Navigation ATM**

SJ1544

Icons will appear on the navigation display, indicating the locations of the selected POI. For further information about POIs, see **135, CATEGORIES AND SUB-CATEGORIES**.