

X-TYPE

Voice Activated Control

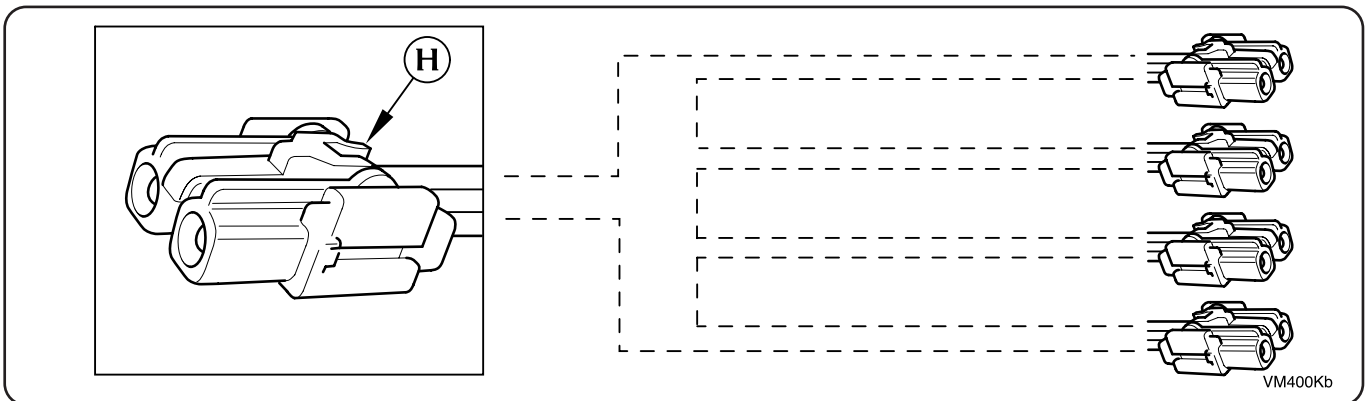
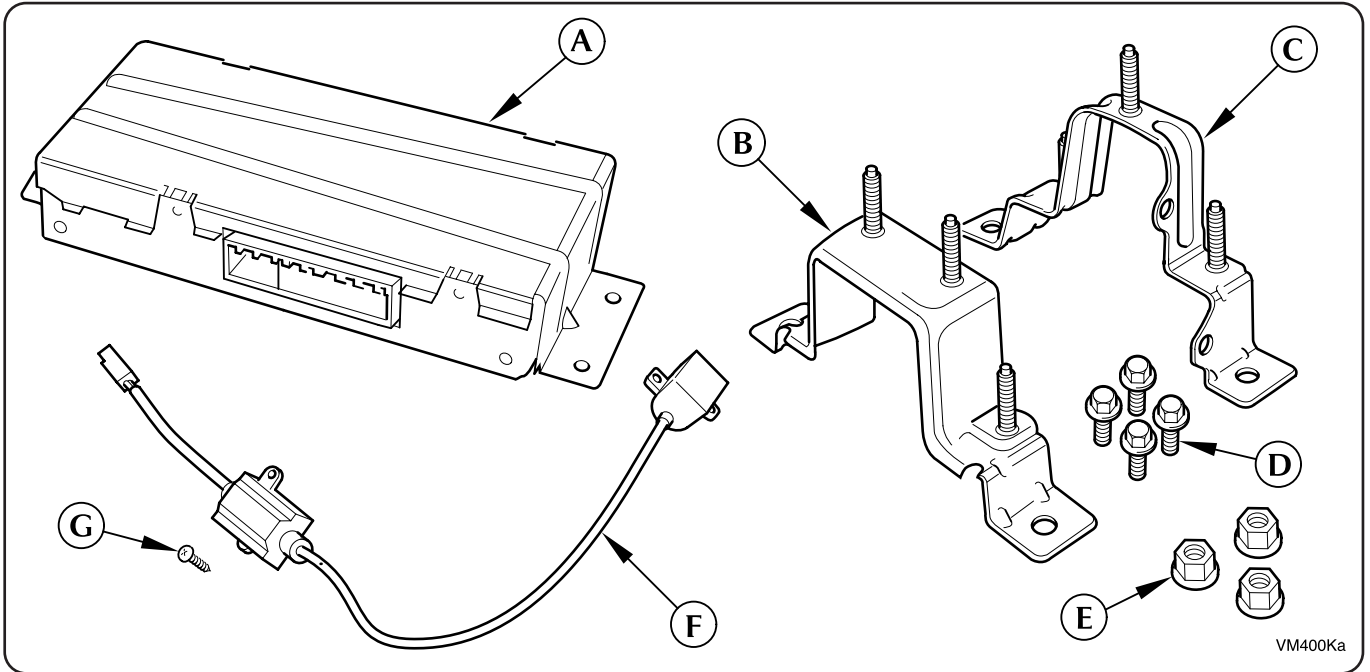

Content of kit

- A. Voice module *
- B. Bracket
- C. Bracket
- D. Bolts
- E. Nuts
- F. Microphone *
- G. Screw
- H. D²b lead *

* Ordered separately

X-TYPE

Voice Activated Control

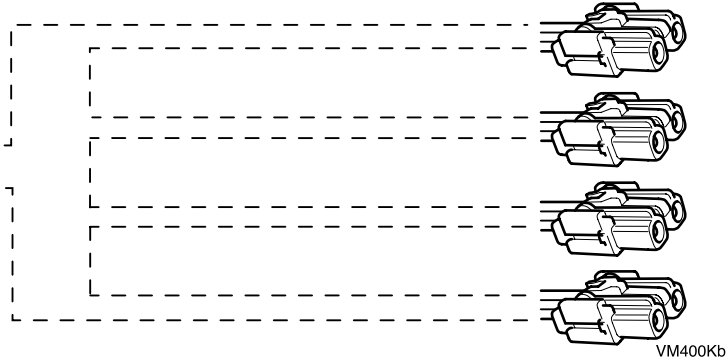
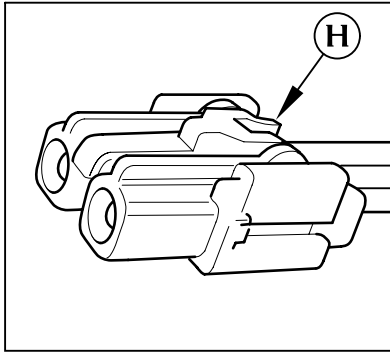

VM400Kb

Notes:

Ensure correct optical lead supplied using matrix below before commencing work.

Locate the column which matches the vehicle specification including voice.

Ensure the letter (*) is the same as the letter (*) in the d²b lead part number.

1X43-14B242 ?*?

		A*	B*	B*	C*	C*	D*	D*	E*	F*	F*	G*	K*	L*	M*	N*
CD	(1)	Y			Y	Y	Y	Y	Y					Y	Y	
PHONE	(2)		Y		Y		Y		Y	Y		Y	Y	Y		
VOICE	(3)			Y		Y		Y	Y		Y	Y	Y	Y		
NAVIGATION	(4)						Y	Y	Y	Y	Y	Y			Y	Y

MY 2001.5

Part No. C2S 23668

X-TYPE

Voice Activated Control

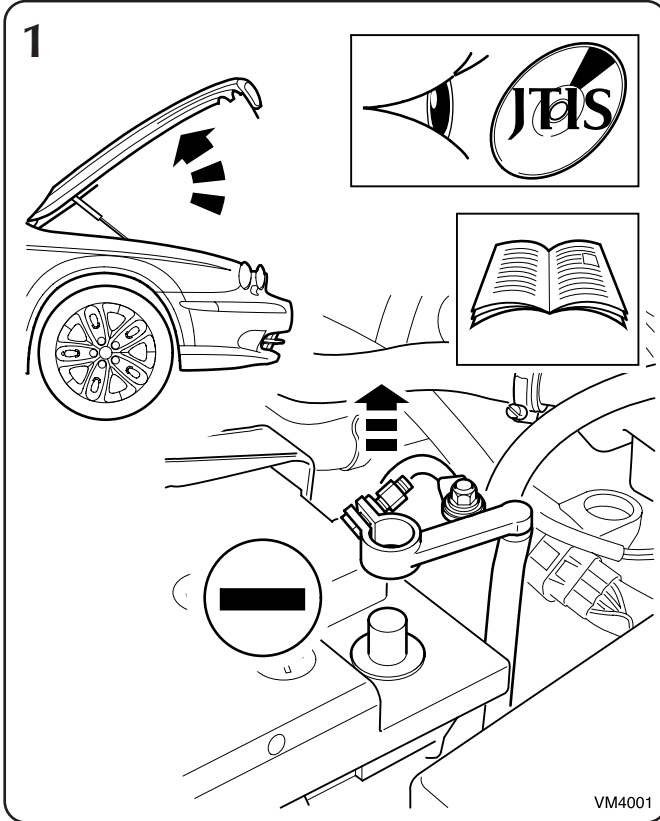

Notes:

1. Refer to J.T.I.S / Drivers Handbook to ensure correct operations are carried out, relevant to battery disconnect and reconnect.

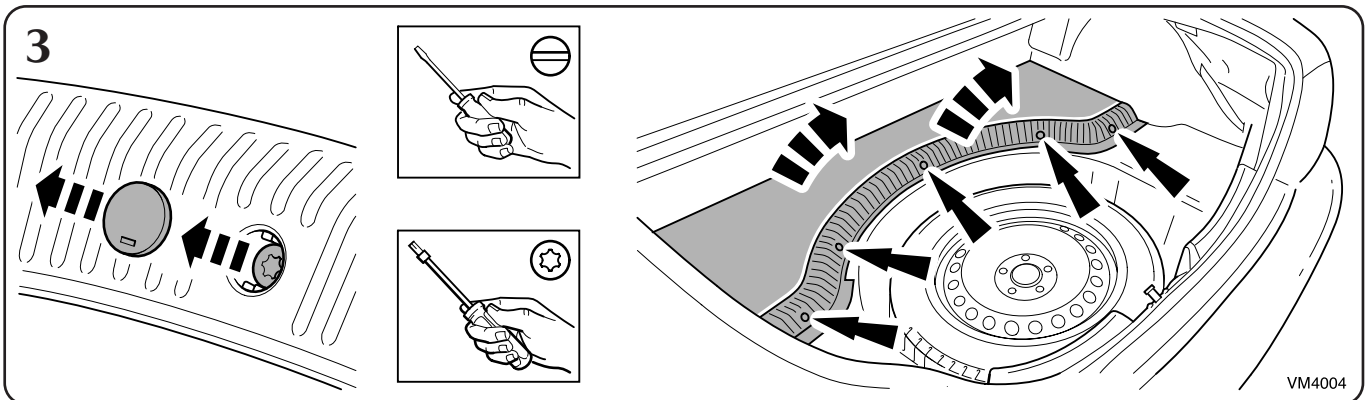
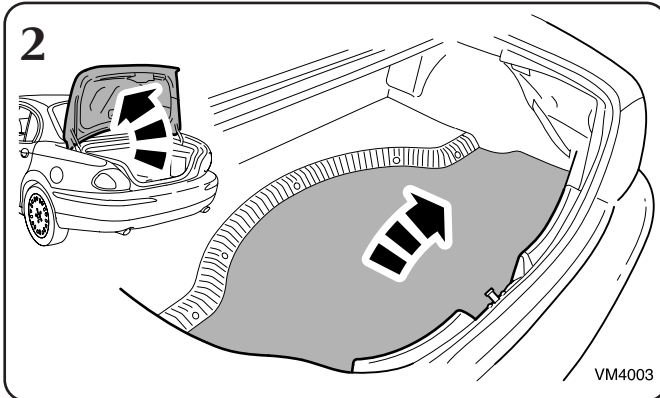

X-TYPE

Voice Activated Control

4

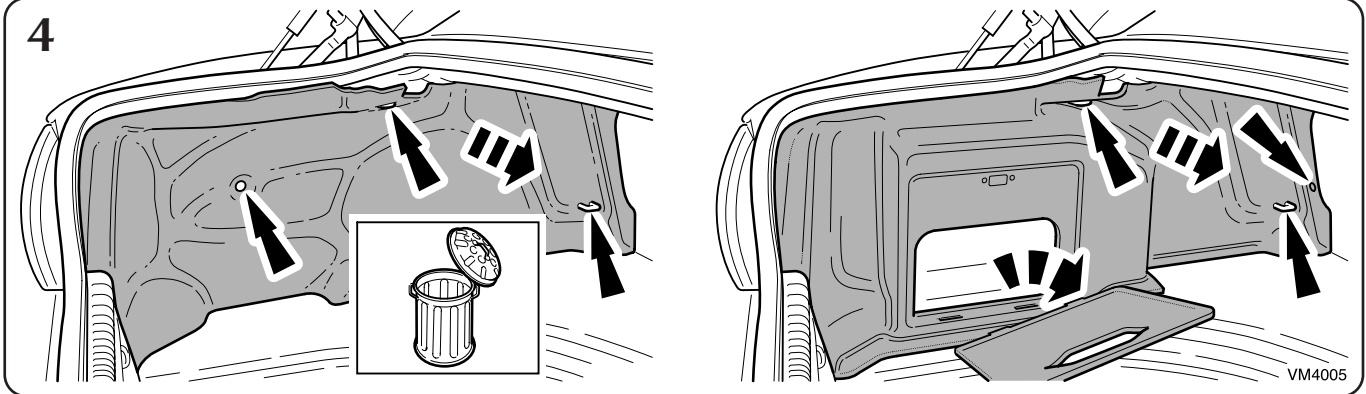

Notes:

4. If new electrical trunk trim supplied, old trunk trim can be discarded after removal.

Notes:

The D²b leads link any modules fitted in the trunk of the vehicle. The following instruction shows disconnecting and reconnecting all the modules that could possibly be fitted. Apply to your vehicle as necessary.

- * Ignore if not fitted.
- # Ignore if already fitted.

X-TYPE

Voice Activated Control

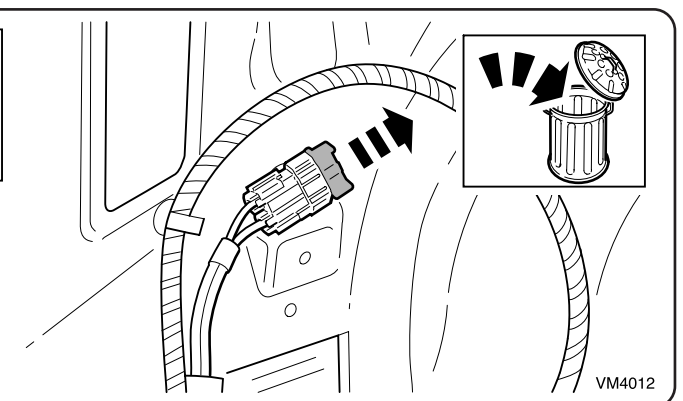
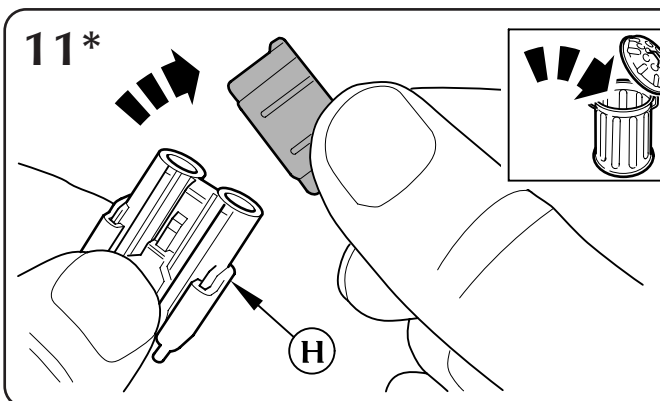
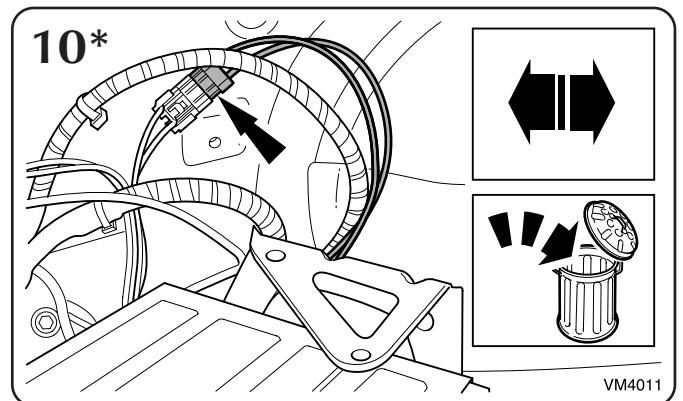
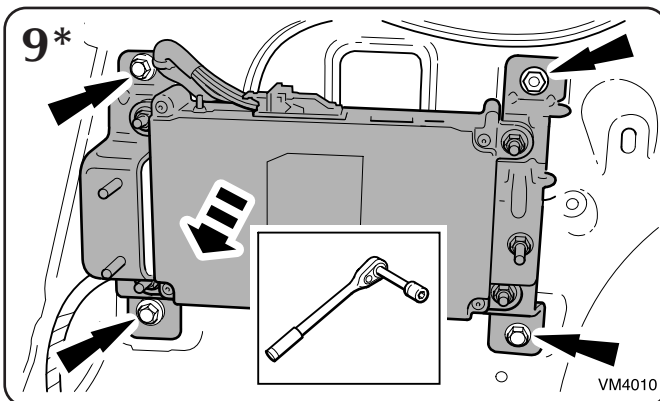
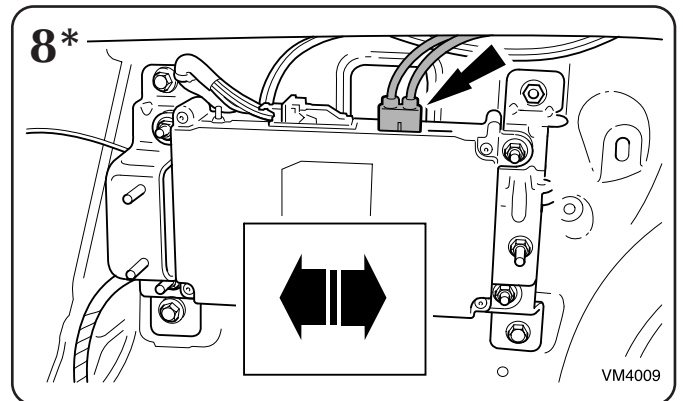
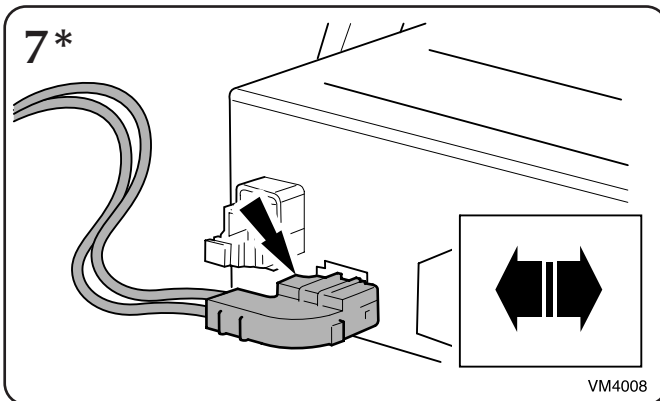
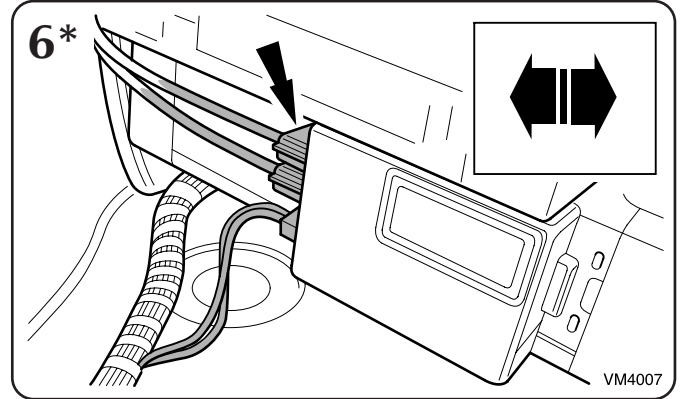
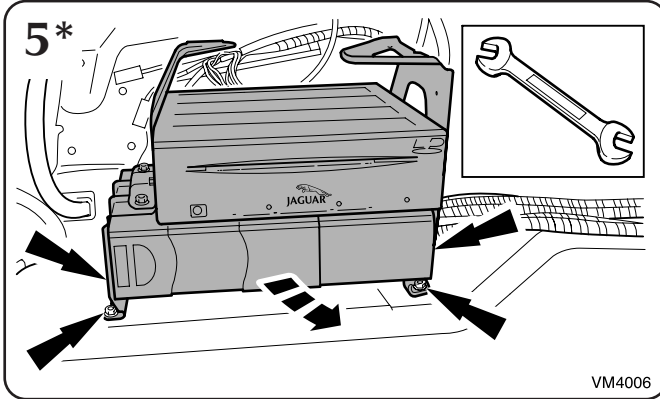

X-TYPE

Voice Activated Control

12

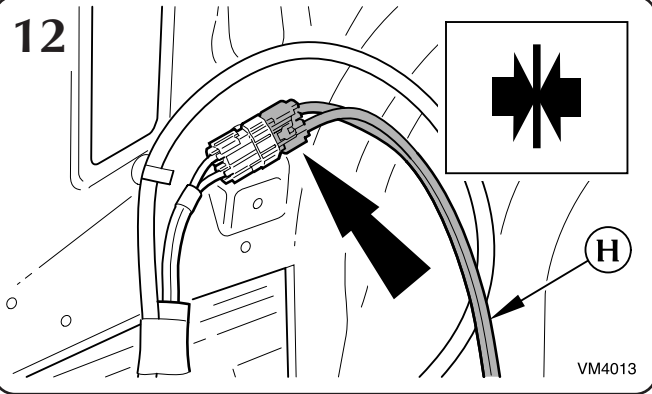

13

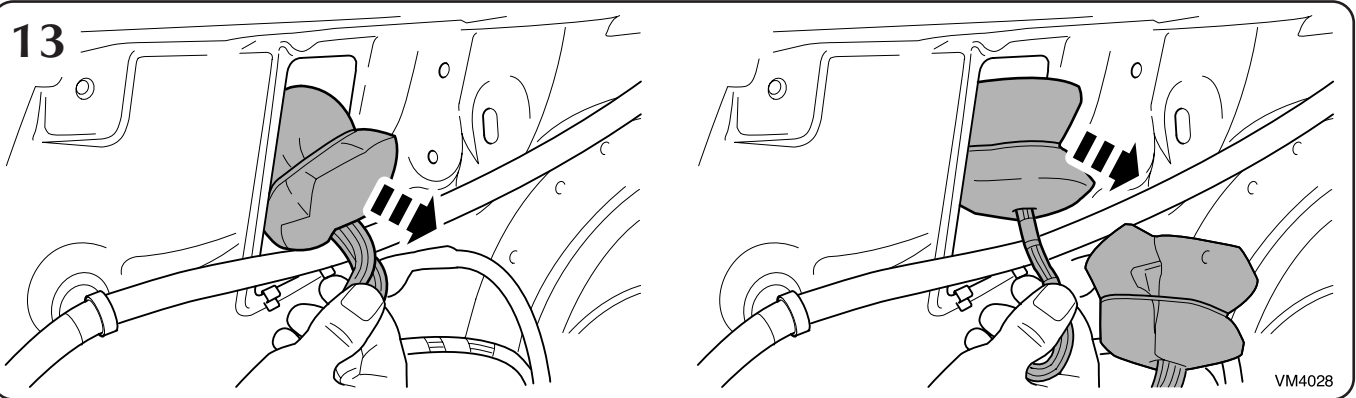

14

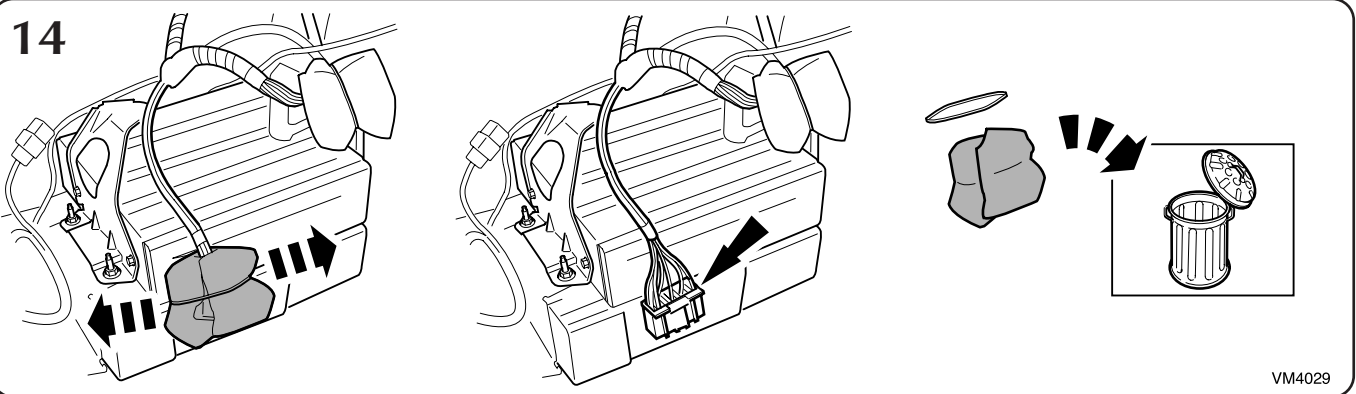

15

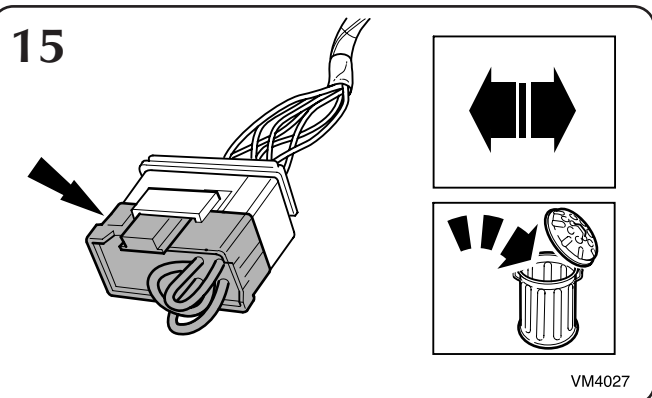

MY 2001.5

Part No. C2S 23668

X-TYPE

Voice Activated Control

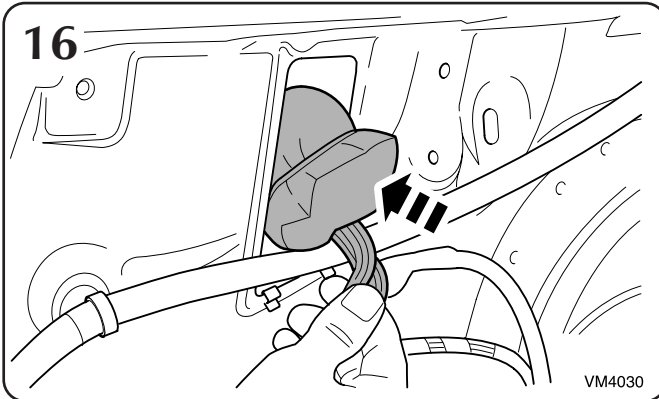

Notes:

16. Foam protection must be fitted if you are replacing the telephone plug in the body hole.

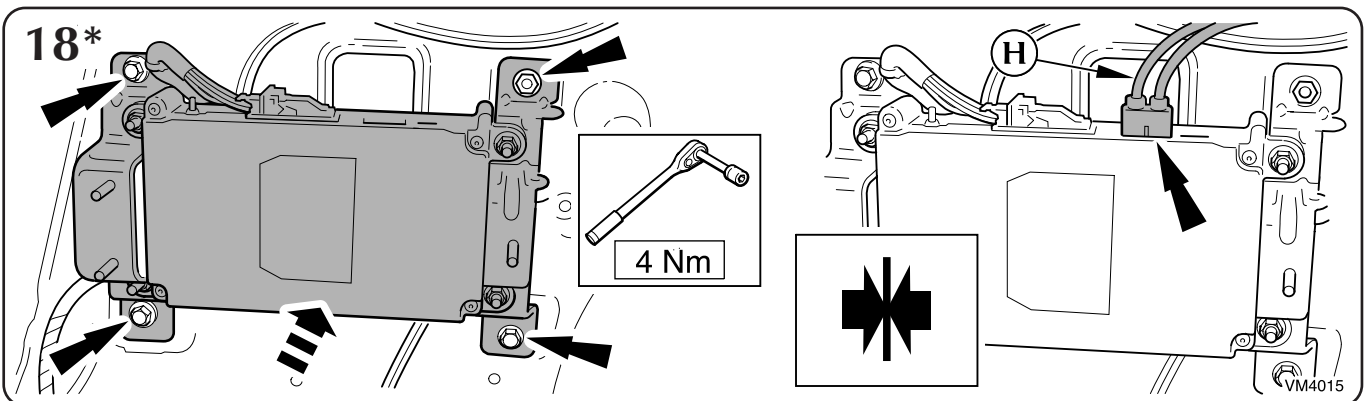
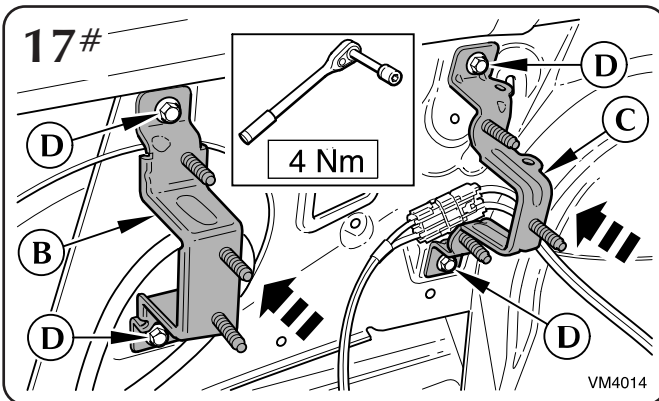

Notes:

18. If the vehicle has telephone, the brackets for voice are already fitted. Mount the voice module in front of the telephone module and discard the brackets and bolts supplied.

X-TYPE

Voice Activated Control

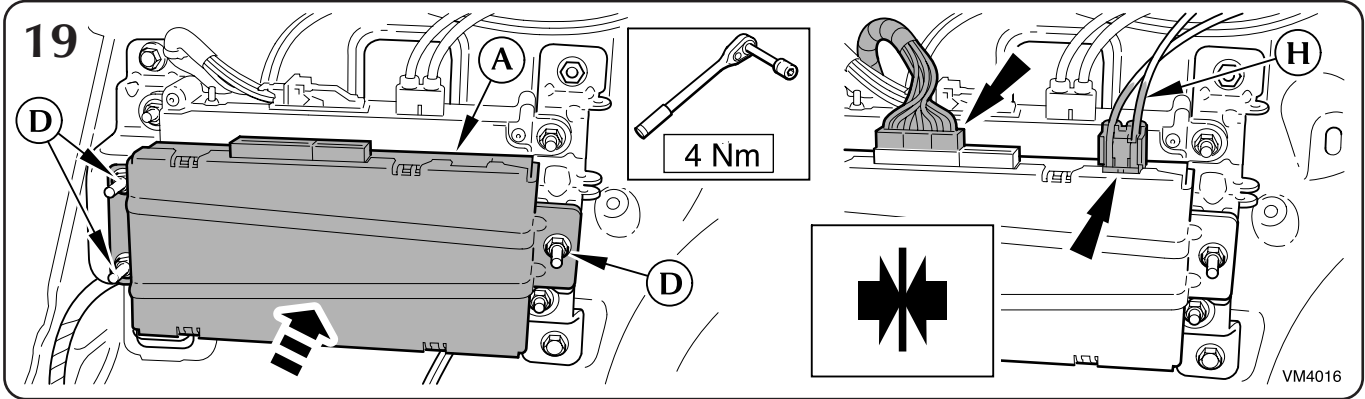

Notes:

19. Telephone module may or may not be fitted.

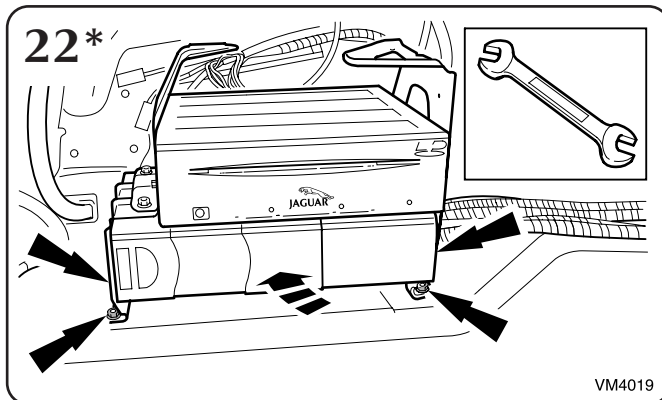
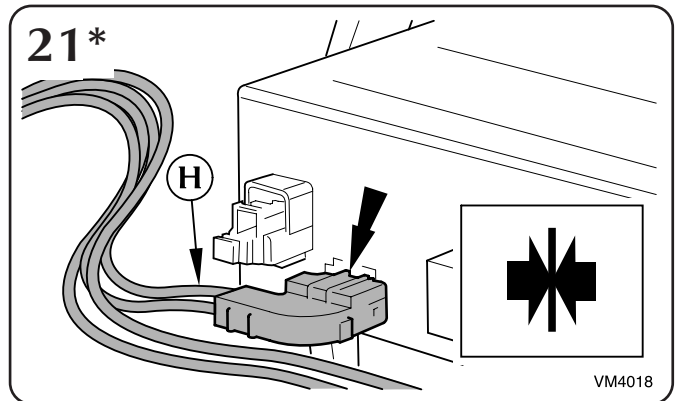
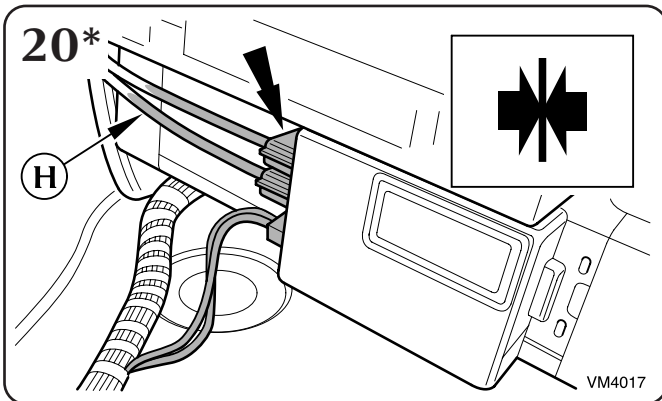

MY 2001.5

Part No. C2S 23668

X-TYPE

Voice Activated Control

23

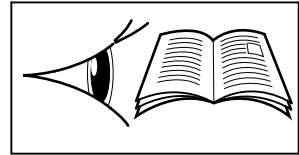
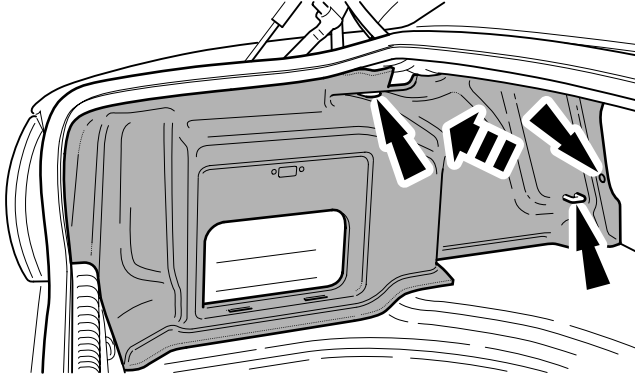

VM4020

Notes:

23. If new trunk trim supplied refer to instructions for trunk modifications.

24

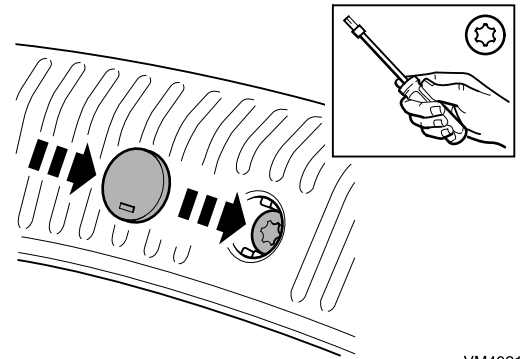
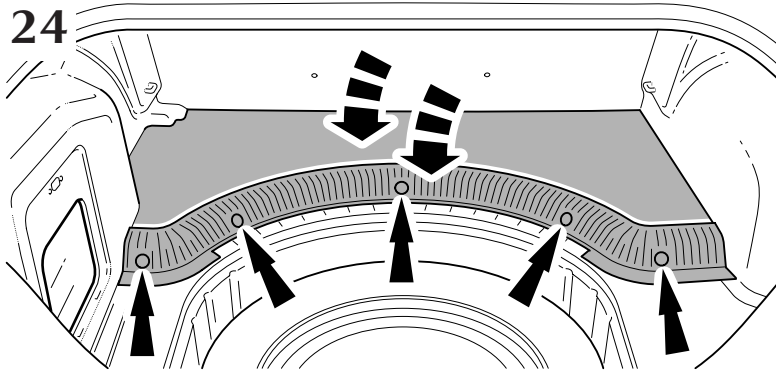

VM4021

25

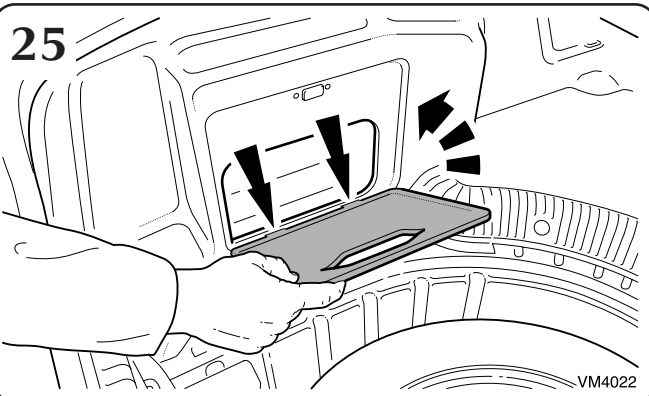

VM4022

26

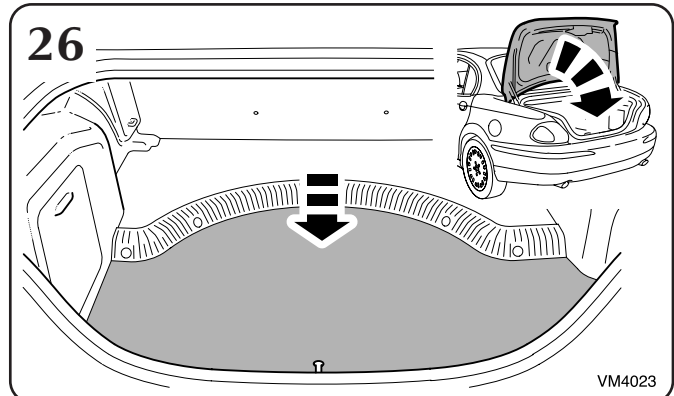

VM4023

X-TYPE

Voice Activated Control

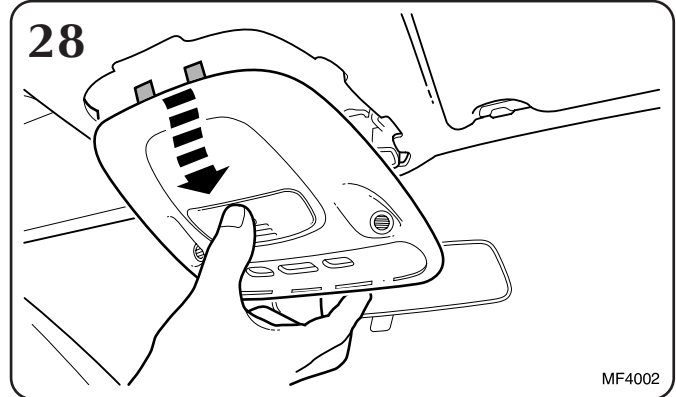
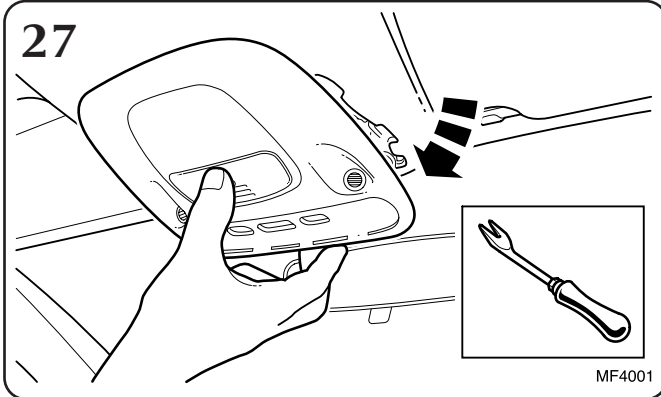

Notes:

Dependant on the vehicle specification operations may vary for fitting the microphone.

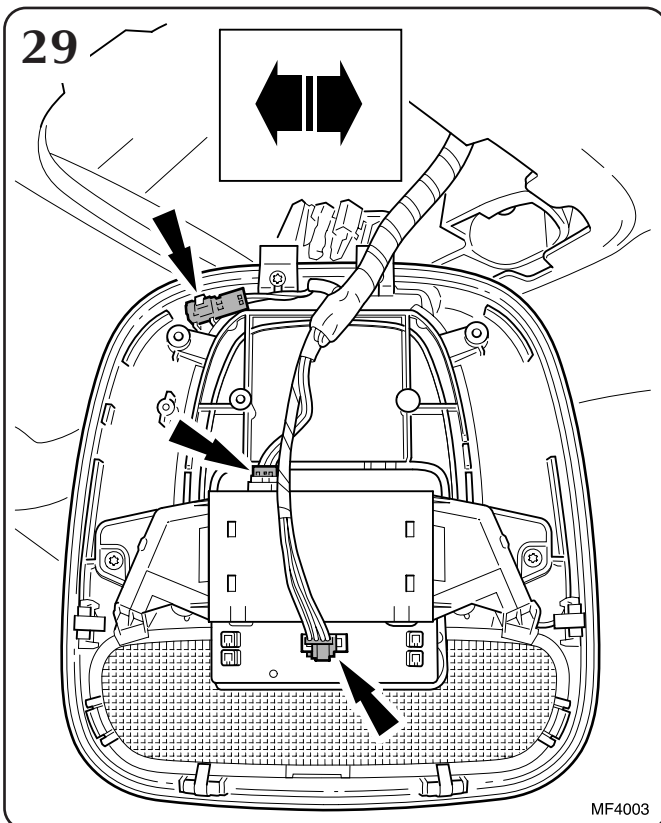

Notes:

29. Disconnect all electrical connectors to enable console to be removed from the vehicle.

MY 2001.5

Part No. C2S 23668

X-TYPE

Voice Activated Control

30a

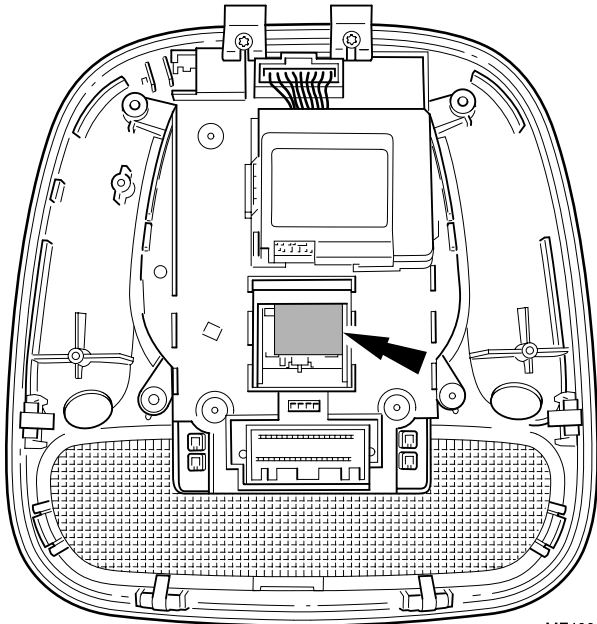

MF4004a

Notes:

30a. Microphone is located in area shown.

30b

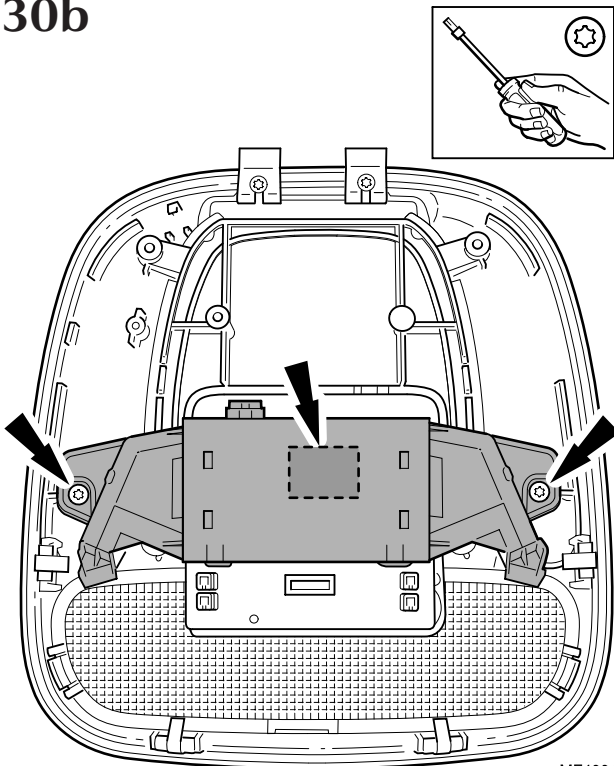

MF4004b

Notes:

30b. Microphone is located in area shown. It may be necessary to remove the ultra sonic alarm module in order to get access.

X-TYPE

Voice Activated Control

31

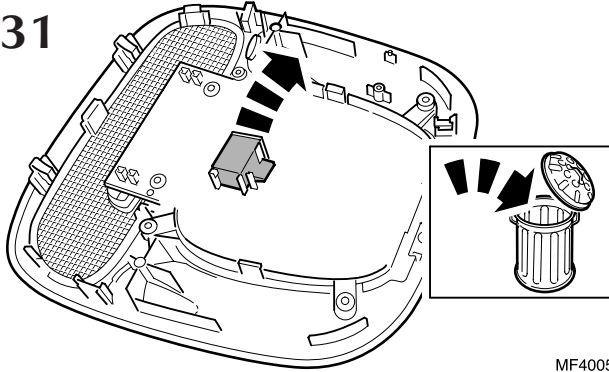

MF4005a

32

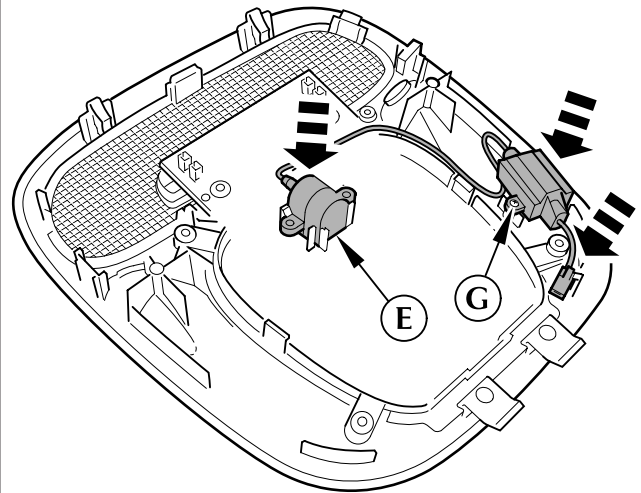
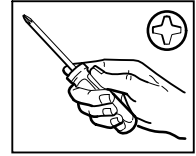

MF4006a

33

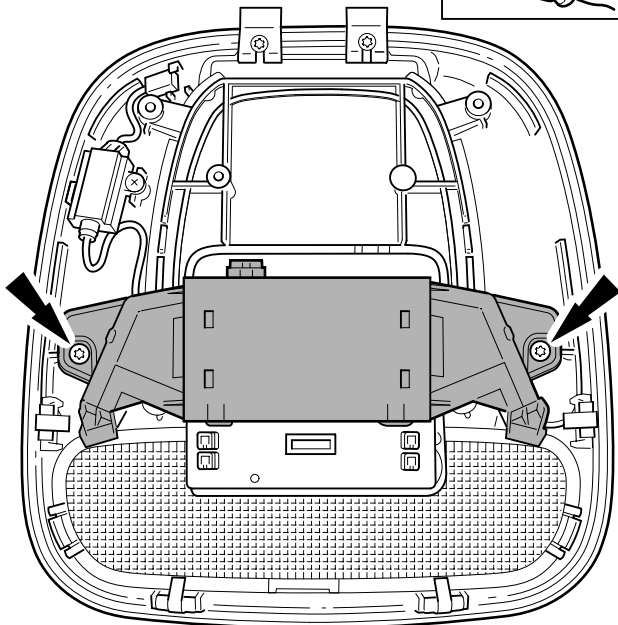
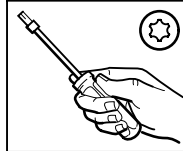

MF4007

Notes:

33. Refit the ultra sonic alarm module if fitted.

MY 2001.5

Part No. C2S 23668

X-TYPE

Voice Activated Control

Notes:

- 34. Connect all electrical connectors.

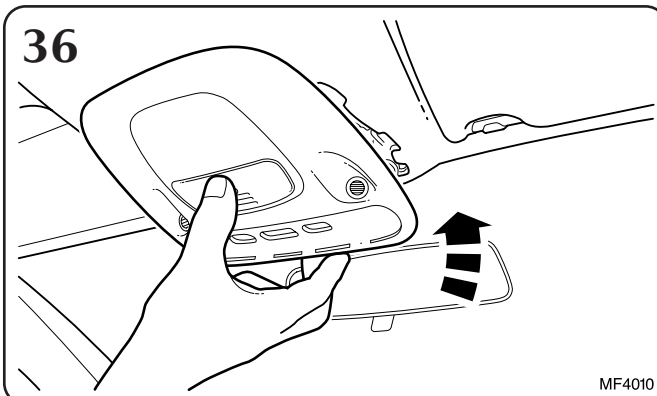
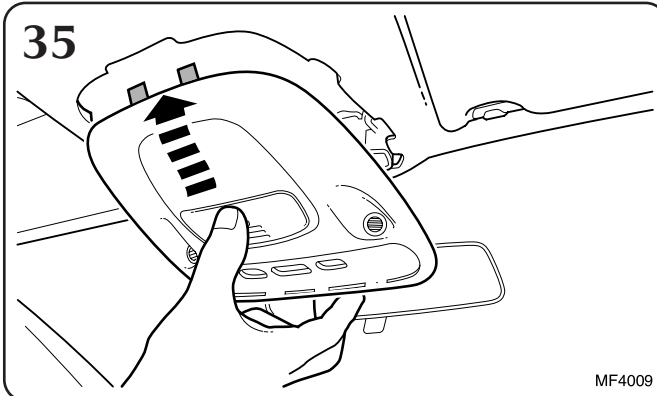
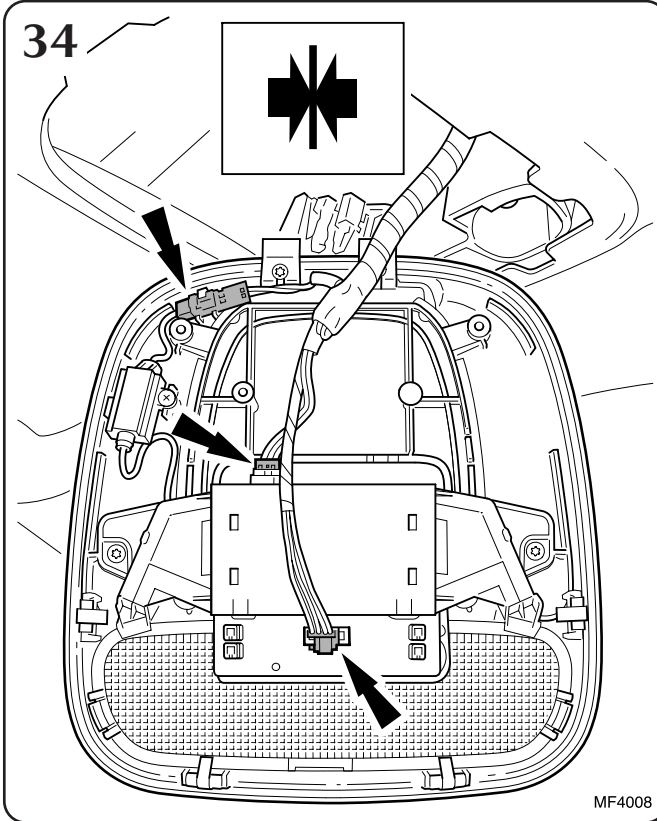

X-TYPE

Voice Activated Control

37

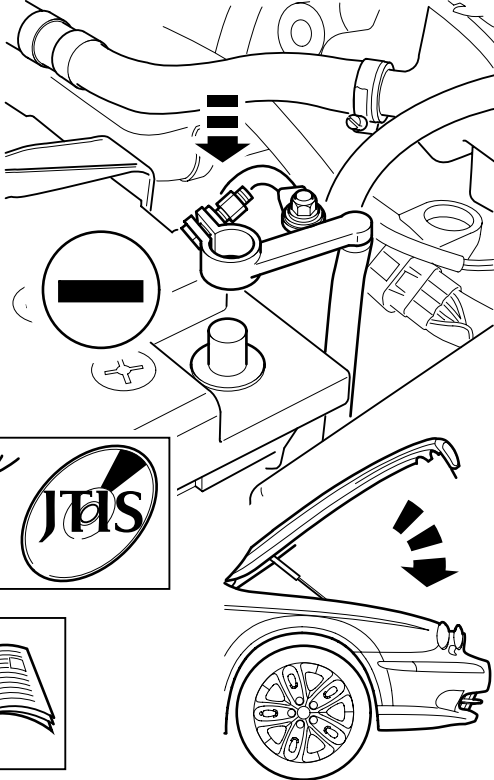

VM4024

Notes:

37. Refer to J.T.I.S / Drivers Handbook to ensure correct operations are carried out, relevant to battery disconnect and reconnect.

38

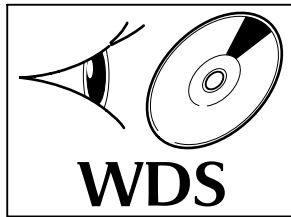

VM4025

Notes:

38. Refer to WDS, dealer options, add and remove accessory.