

**Audio Connectivity Module, Module de Connectivité Audio,  
Audio-Anschaltmodul, Modulo per Connettività Avanzata,  
Módulo de Conectividad de Audio,**

**X-TYPE**

Jaguar accessory fitting instructions can be found at the URL below:

Les instructions de montage Jaguar sont disponibles à l'adresse Web ci-dessous :

Zu Einbauanweisungen für Jaguar-Zubehörteile siehe nachstehende URL:

Las instrucciones de montaje de accesorios de Jaguar se pueden encontrar en el URL siguiente:

Le istruzioni di montaggio accessori Jaguar si trovano all'indirizzo riportato qui sotto:

[www.jaguartechno.com/extfree2viewjagprod/index.jsp](http://www.jaguartechno.com/extfree2viewjagprod/index.jsp)



**FITTING INSTRUCTIONS, INSTRUCTIONS DE MONTAGE,  
EINBAUANLEITUNG, ISTRUZIONI DI MONTAGGIO,  
INSTRUCCIONES DE MOTAJE,**

**X- Type**

**Audio Connectivity Module, Module de connectivité audio,  
Audio-anschlusmodul, Modulo per connettività avanzata,  
Módulo de conectividad de audio**

**NOTE:**

1. This module is designed to emulate the CD Changer functionality.
2. This module is suitable for all levels of audio systems, (non-touch screen and touch screen).
3. If there are no other modules on the vehicle's 'Optical Network' i.e. telephone, Navigation or Voice, the fibre Optic Loop should be used.
4. If there is no CD Changer fitted, the vehicle may need programming via WDS/IDS to enable the CD Changer functionality.

**NOTE:**

1. Ce module est conçu pour émuler la fonctionnalité CD Changer.
2. Ce module est compatible avec tous les types de système audio (à écran tactile ou non).
3. Si aucun autre module n'est présent sur le 'réseau optique' du véhicule, c'est-à-dire téléphone, aide à la navigation ou voix, utiliser le circuit fibre optique.
4. Si le véhicule n'est pas équipé d'un chargeur de CD, il pourra être nécessaire de le programmer à l'aide du WDS/IDS pour activer la fonction CD Changer.

**Hinweis:**

1. Dieses Modul emuliert die Funktion des CD-Wechslers.
2. Dieses Modul eignet sich für alle Audiosystem-Versionen (mit und ohne Touchscreen).
3. Sind keine weiteren Module, d. h. Telefon, Navigationssystem oder Sprachsteuerung mit dem Lichtleiternetzwerk des Fahrzeugs verbunden, muss die Lichtwellenleiterschleife verwendet werden.
4. Ist kein CD-Wechsler eingebaut, muss das Fahrzeug möglicherweise mit WDS/IDS programmiert werden, damit die Funktion des CD-Wechslers gewährleistet ist.

**Nota:**

1. Este módulo está diseñado para emular el cargador de CD.
2. Este módulo es compatible con todos los niveles de sistema de audio (con pantalla táctil y sin pantalla táctil).
3. Si en la "red óptica" del vehículo no hay más módulos, p. ej., teléfono, navegación o voz, se debe utilizar el anillo de fibra óptica.
4. Si el vehículo no está equipado con un cargador de CD, puede ser necesario programar el vehículo con el WDS/IDS para habilitar la función de cargador de CD.

**Nota:**

1. Questo modulo è progettato per emulare la funzione del CD Changer.
2. Il modulo è adatto per tutte le categorie di sistema audio (con e senza schermo a sfioramento)
3. Se non vi sono altri moduli sulla rete ottica del veicolo, cioè telefono, sistema di navigazione o comando vocale, si deve utilizzare il cablaggio a fibre ottiche.
4. Se il CD Changer non è in dotazione, potrebbe essere necessario programmare il veicolo tramite WDS/IDS per abilitare la funzione del CD Changer.

**MY 2001 →**

**Part No. C2S 46365**



**FITTING INSTRUCTIONS, INSTRUCTIONS DE MONTAGE,  
EINBAUANLEITUNG, ISTRUZIONI DI MONTAGGIO,  
ISTRUCCIONES DE MOTAJE,**

**X- Type**

**Audio Connectivity Module, Module de connectivité audio,  
Audio-anschaltmodul, Modulo per connettività avanzata,  
Módulo de conectividad de audio**

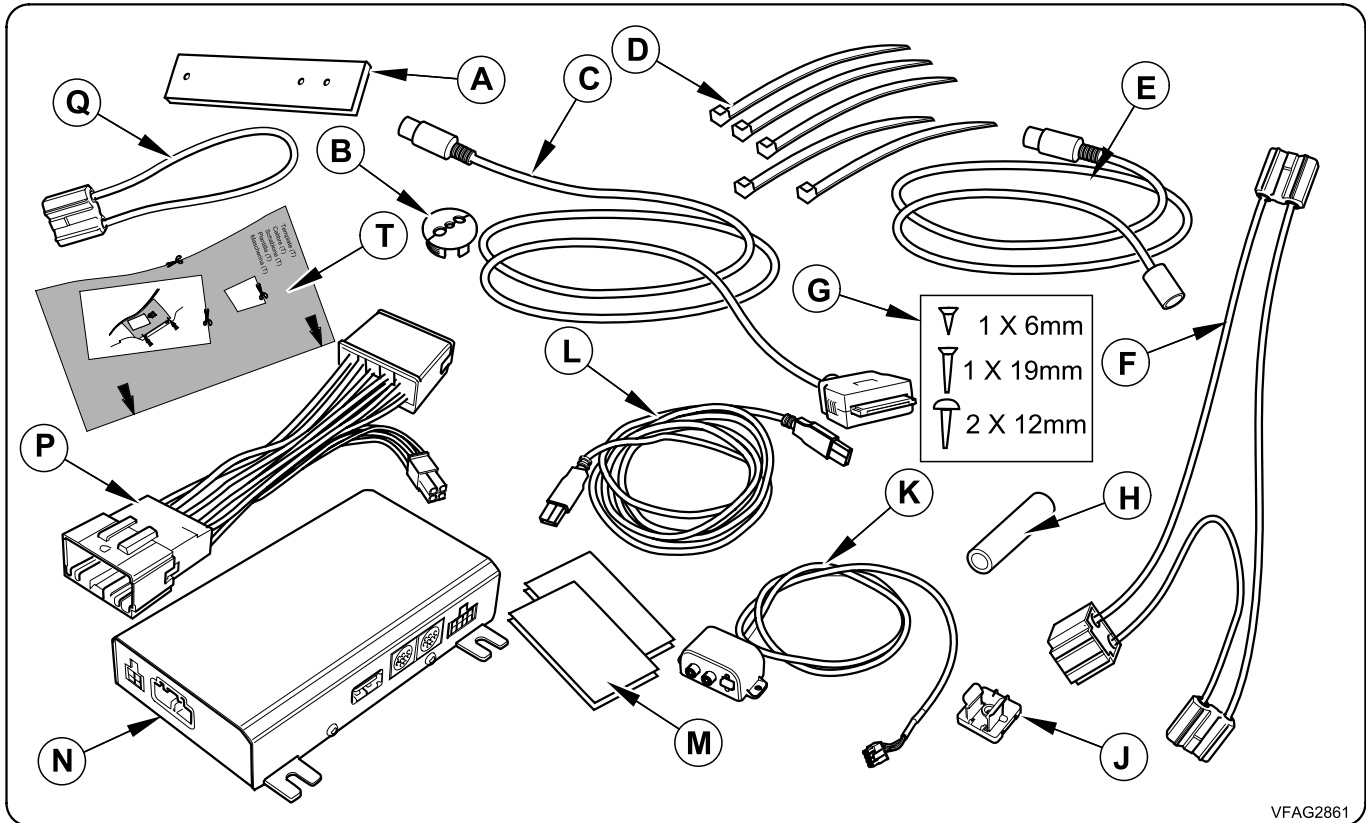

VFAG2861

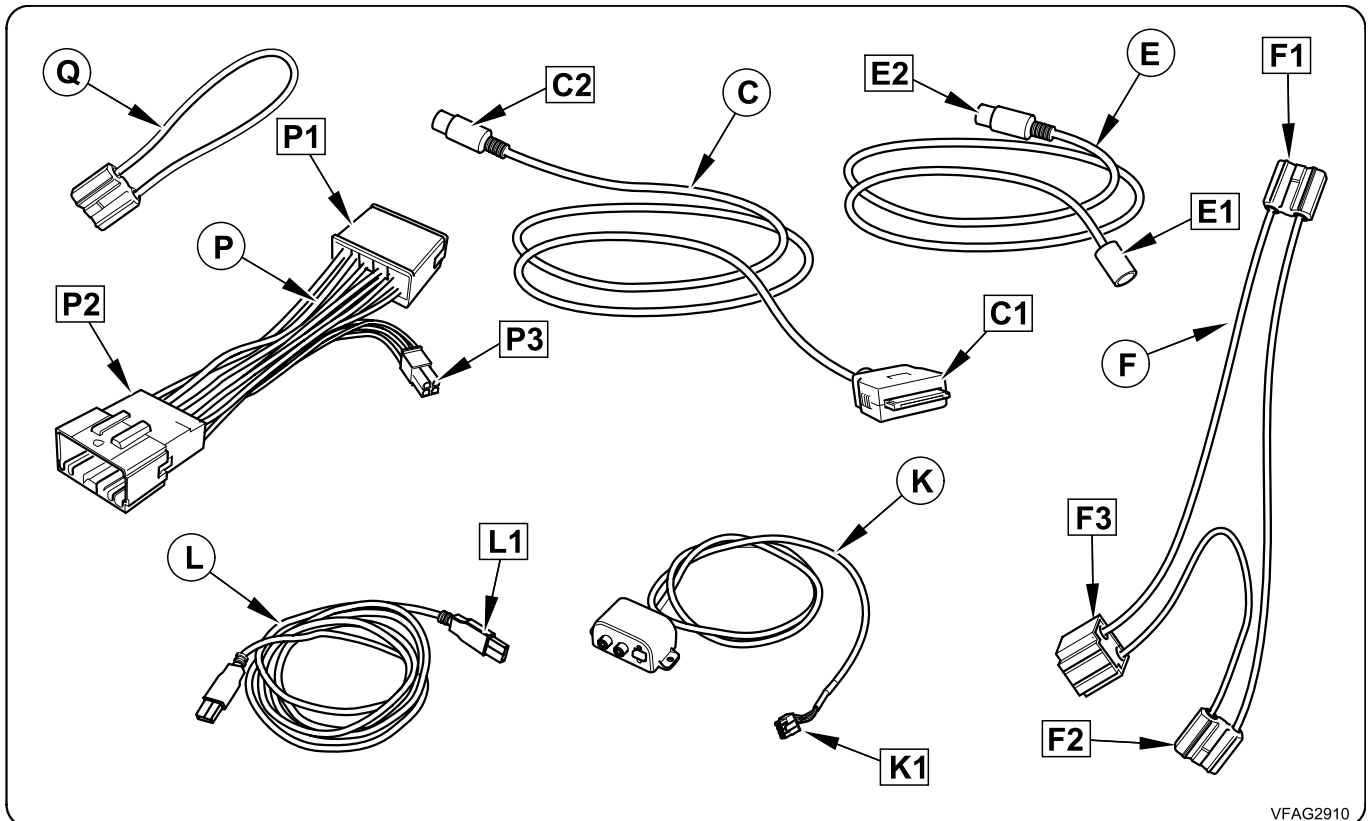

VFAG2910

**MY 2001 →**

**Part No. C2S 46365**



JAGUAR

FITTING INSTRUCTIONS, INSTRUCTIONS DE MONTAGE, EINBAUANLEITUNG, ISTRUZIONI DI MONTAGGIO, INSTRUCCIONES DE MOTAJE,

X- Type

Audio Connectivity Module, Module de connectivité audio, Audio-anschlusmodul, Modulo per connettività avanzata, Módulo de conectividad de audio

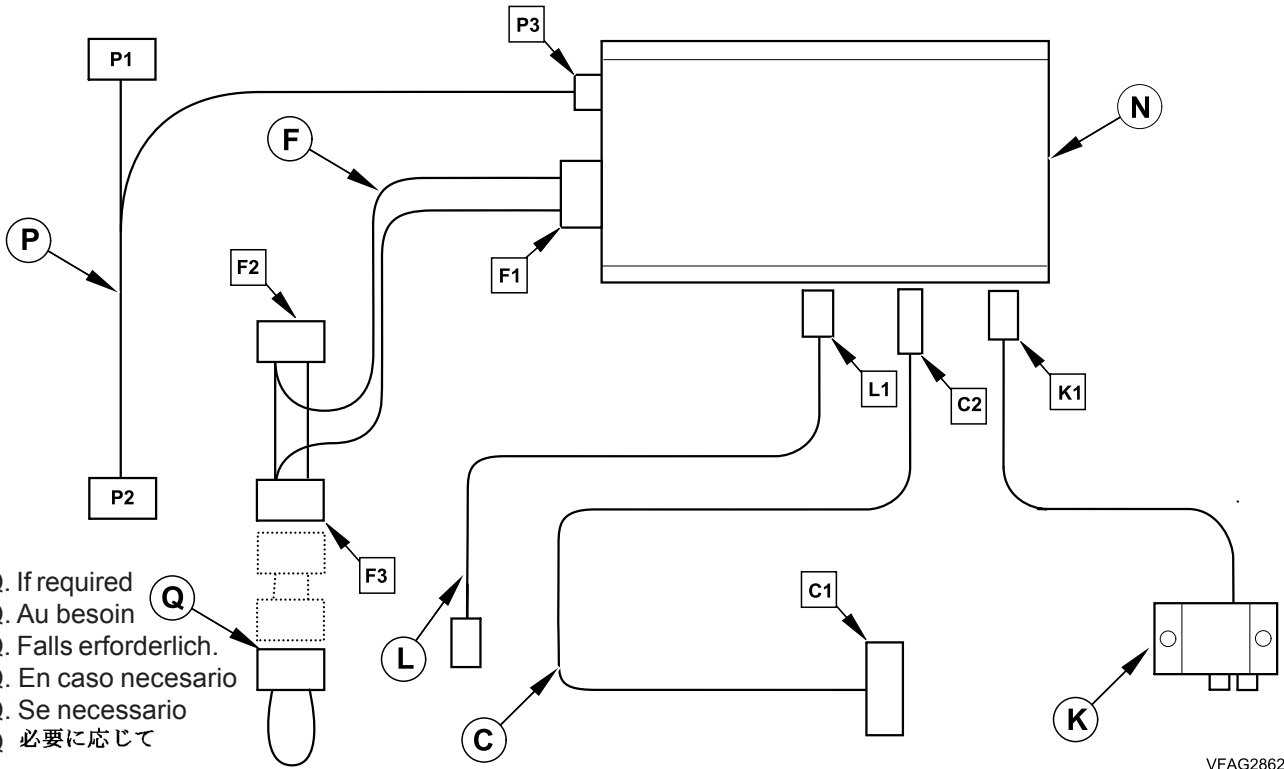

VFAG2862

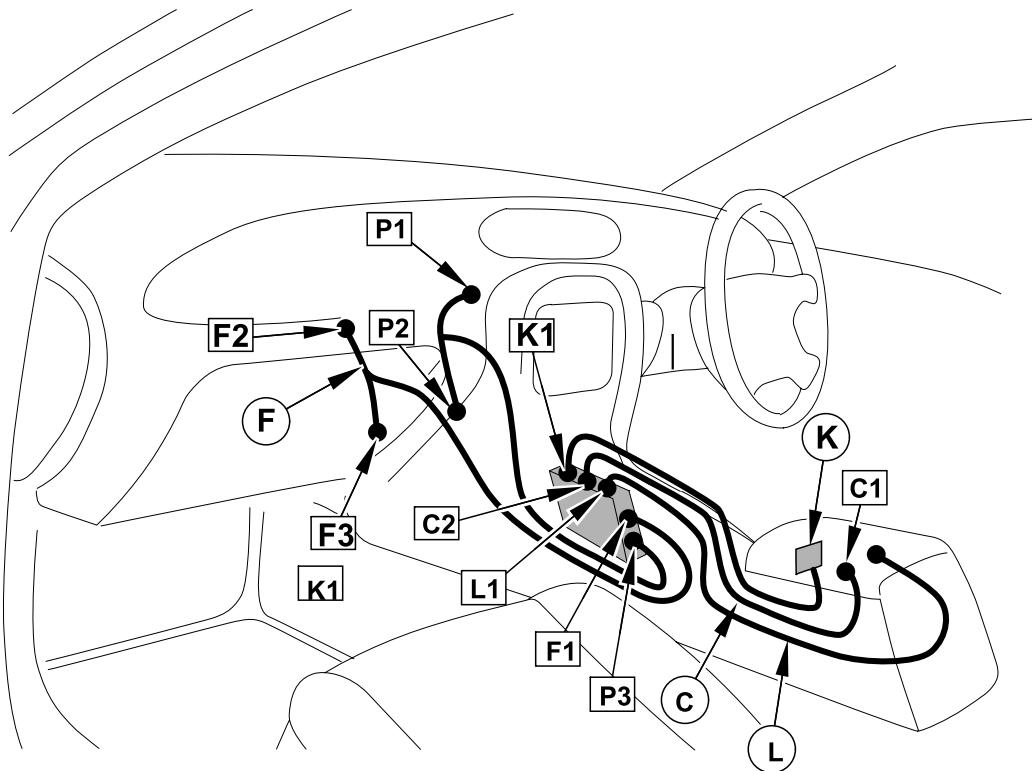

VFAG3509

MY 2001 →

Part No. C2S 46365



# FITTING INSTRUCTIONS, INSTRUCTIONS DE MONTAGE, EINBAUANLEITUNG, ISTRUZIONI DI MONTAGGIO, INSTRUCCIONES DE MOTAJE,

## X- Type

### Audio Connectivity Module, Module de connectivité audio, Audio-anschaltmodul, Modulo per connettività avanzata, Módulo de conectividad de audio

Notes : Hinweise : Note : Nota

1. Refer to GTR / Drivers Handbook to ensure correct operations are carried out, relevant to battery disconnect and reconnect.
1. Se reporter au GTR / Manuel de l'utilisateur pour pouvoir effectuer les opérations correctes, applicables au débranchement et au branchement de la batterie.
1. Zur korrekten Durchführung der Arbeitsschritte beim Ab- und Anklemmen der Batterie siehe GTR/Fahrzeug-Bedienungsanleitung.
1. comprobar que se realizan las operaciones correspondientes relativas a la desconexión y conexión de la batería.
1. Vedere il GTR / Manuale del proprietario per accertarsi di eseguire le operazioni corrette, per ciò che concerne lo scollegamento e il collegamento della batteria.

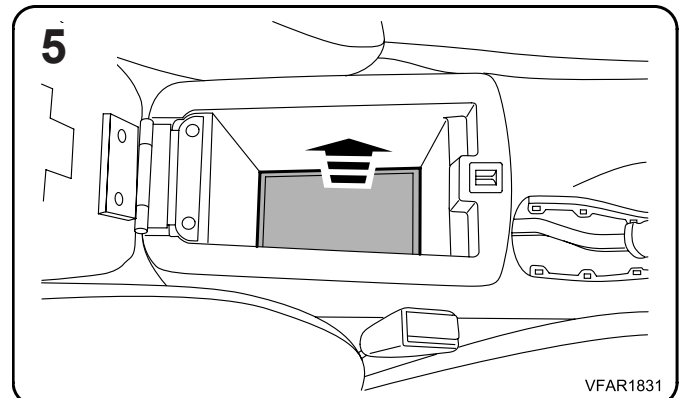
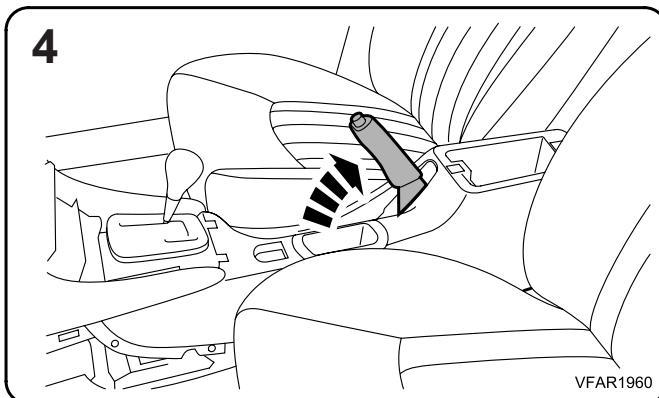
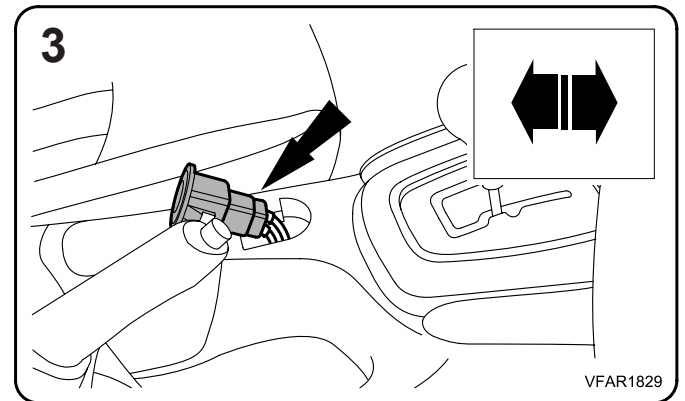
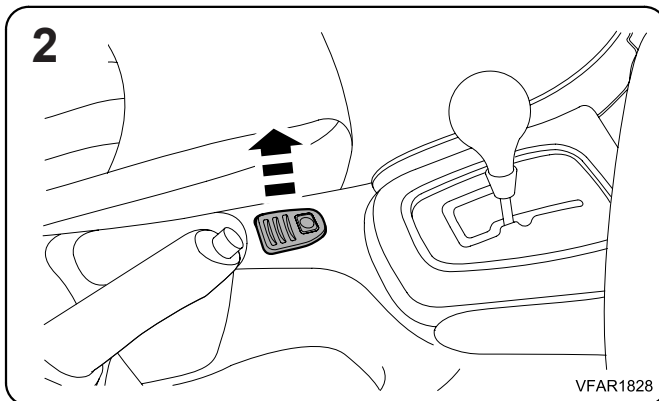
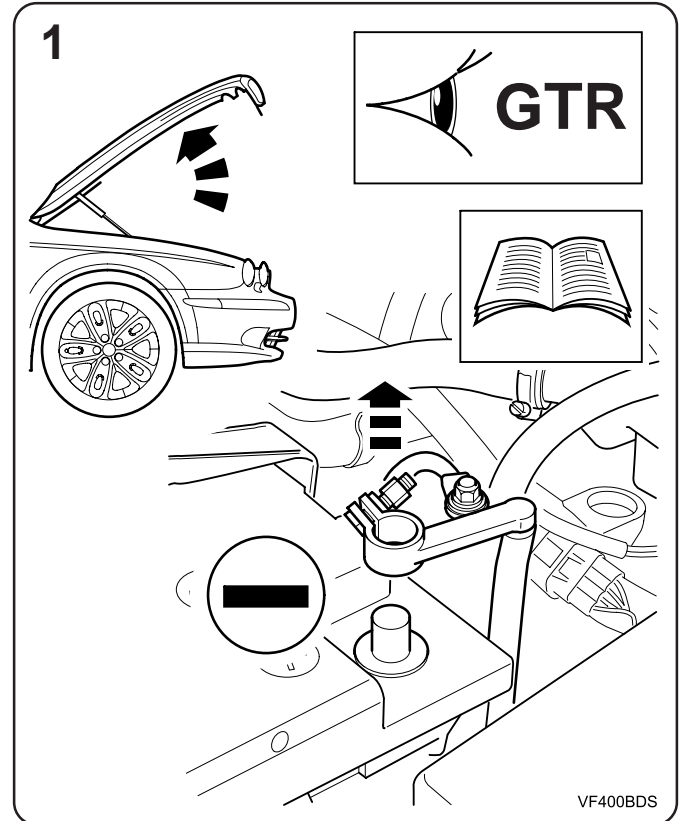

MY 2001 →

Part No. C2S 46365



JAGUAR

FITTING INSTRUCTIONS, INSTRUCTIONS DE MONTAGE,  
EINBAUANLEITUNG, ISTRUZIONI DI MONTAGGIO,  
INSTRUCCIONES DE MONTAJE,

X- Type

Audio Connectivity Module, Module de connectivité audio,  
Audio-anschlusmodul, Modulo per connettività avanzata,  
Módulo de conectividad de audio

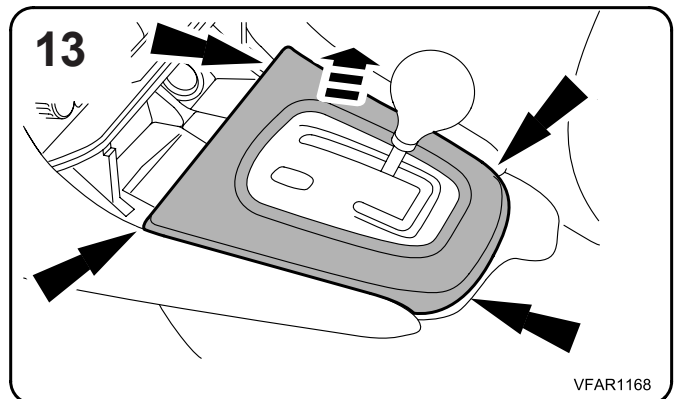
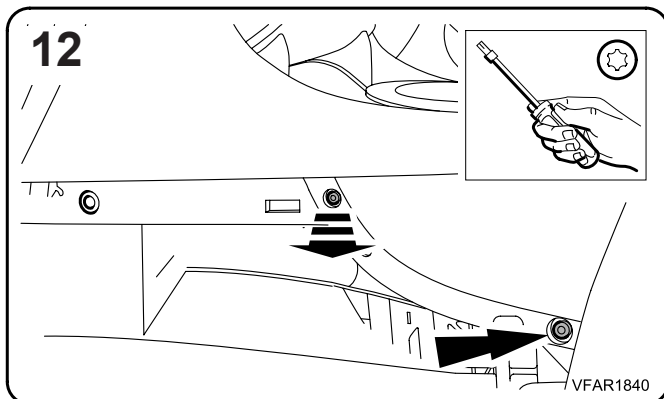
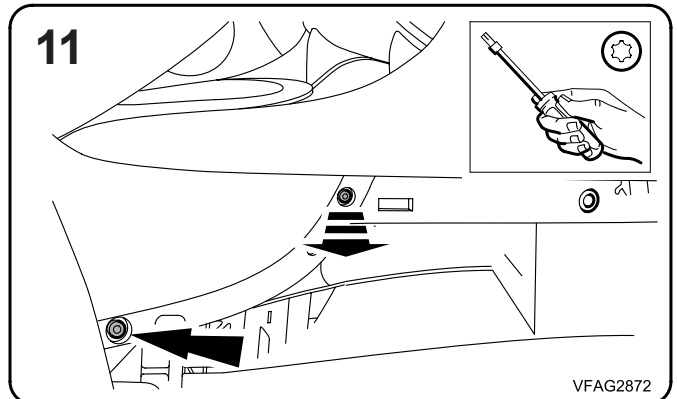
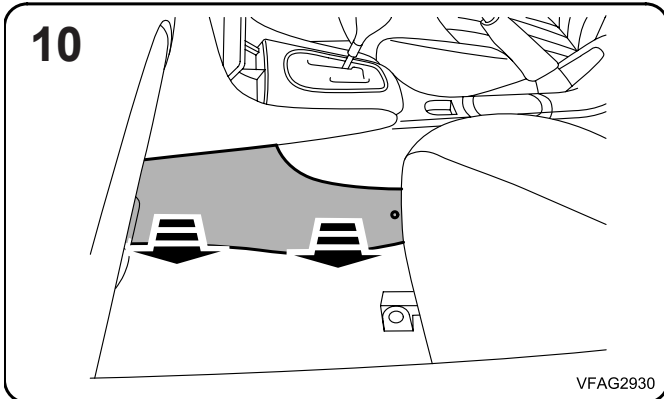
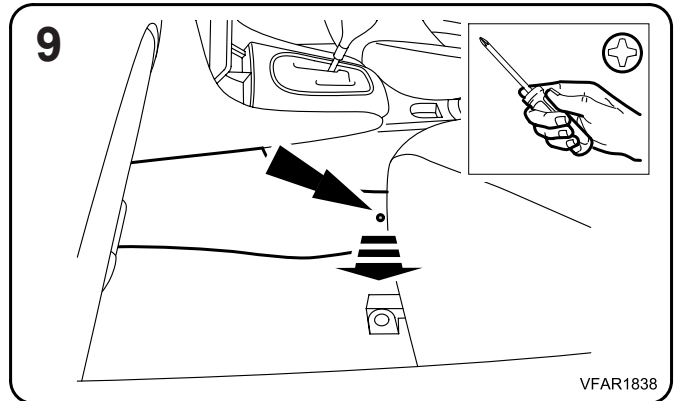
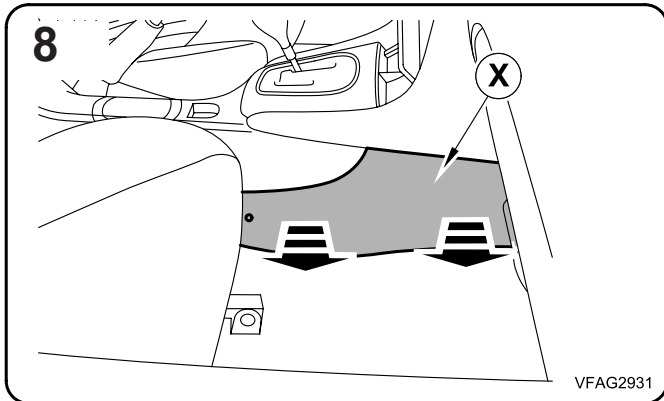
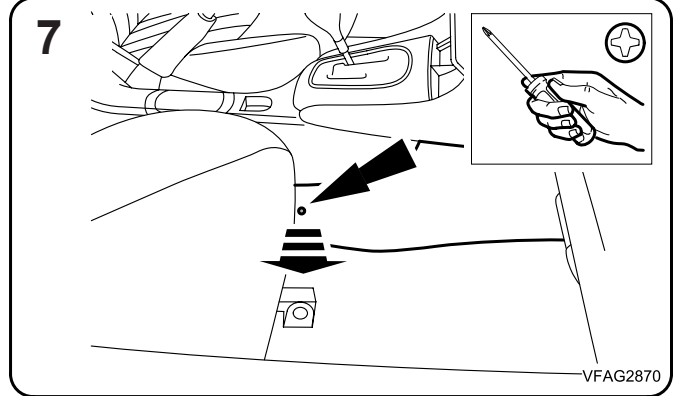
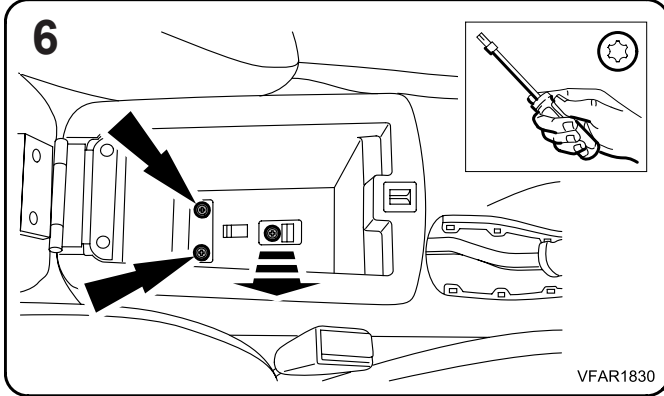

MY 2001 →

Part No. C2S 46365



FITTING INSTRUCTIONS, INSTRUCTIONS DE MONTAGE,  
EINBAUANLEITUNG, ISTRUZIONI DI MONTAGGIO,  
INSTRUCCIONES DE MONTAJE,

X- Type

Audio Connectivity Module, Module de connectivité audio,  
Audio-anschaltmodul, Modulo per connettività avanzata,  
Módulo de conectividad de audio

14

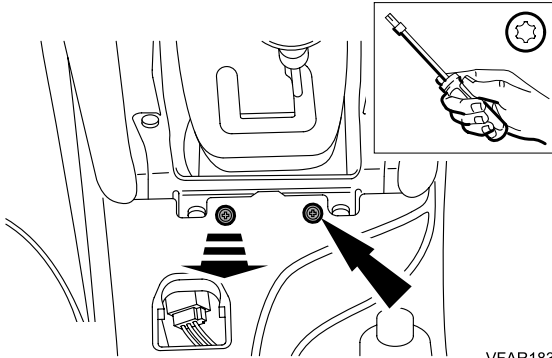

VFAR1833

Notes: Hinweise: Note: Nota:

- 15. Vehicles fitted with Bluetooth telephone module.
- 15. Véhicules munis d'un module de téléphone Bluetooth.
- 15. Fahrzeuge mit Bluetooth-Telefon
- 15. Vehículos equipados con módulo de teléfono Bluetooth.
- 15. Veicoli dotati di modulo telefono Bluetooth.

15.

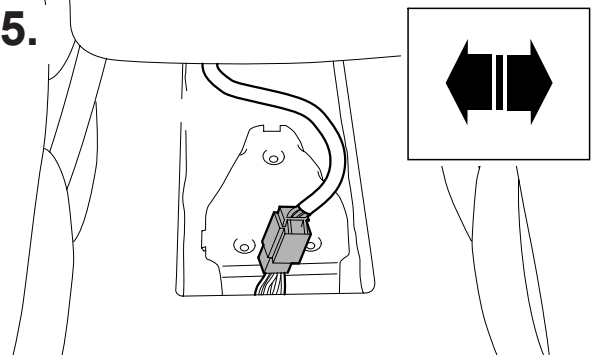

VFAR1841

16

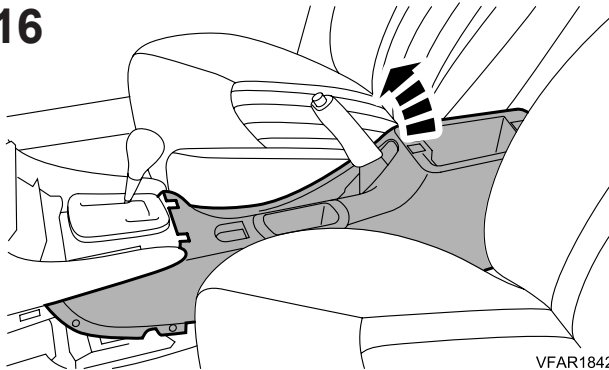

VFAR1842

17

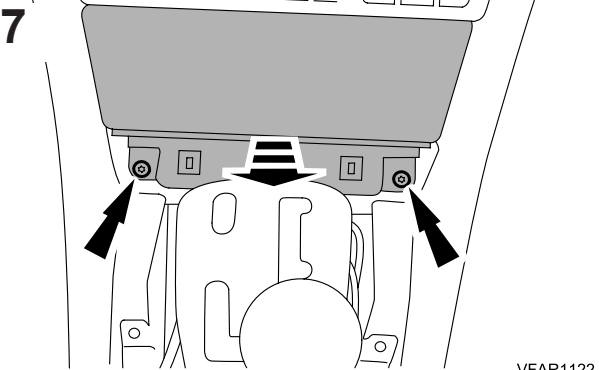

VFAR1122

18

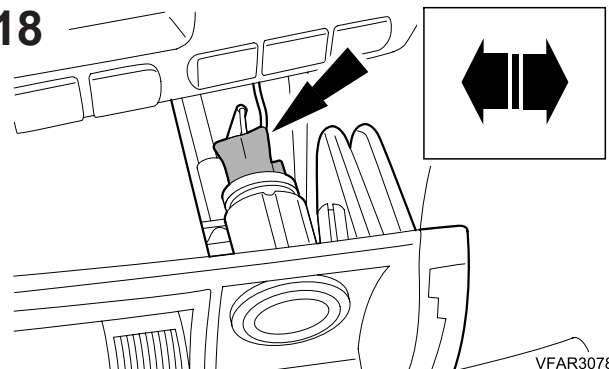

VFAR3078

19

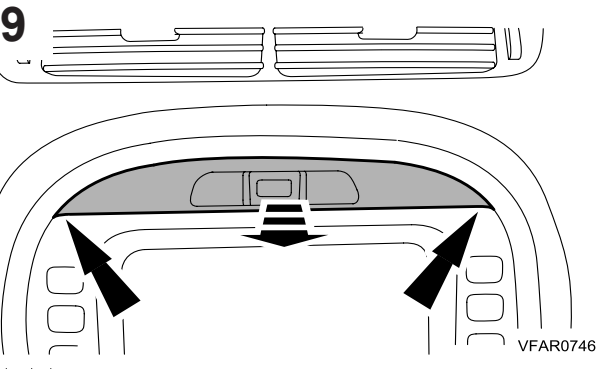

VFAR0746

MY 2001 →

Part No. C2S 46365



**FITTING INSTRUCTIONS, INSTRUCTIONS DE MONTAGE,  
EINBAUANLEITUNG, ISTRUZIONI DI MONTAGGIO,  
INSTRUCCIONES DE MOTAJE,**

**X- Type**

**Audio Connectivity Module, Module de connectivité audio,  
Audio-anschlusmodul, Modulo per connettività avanzata,  
Módulo de conectividad de audio**

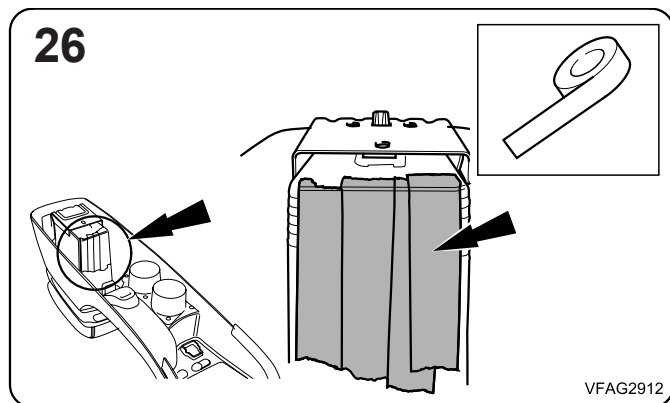
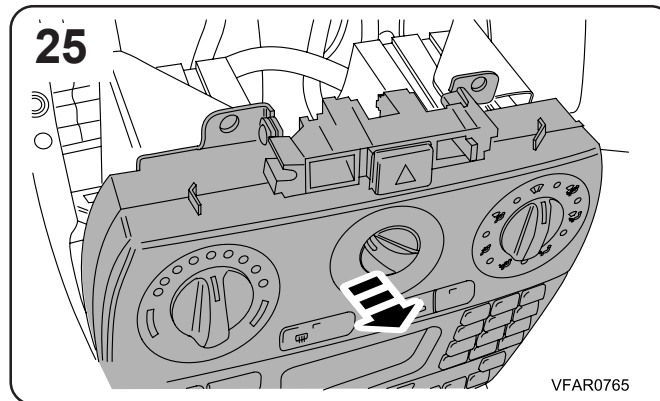
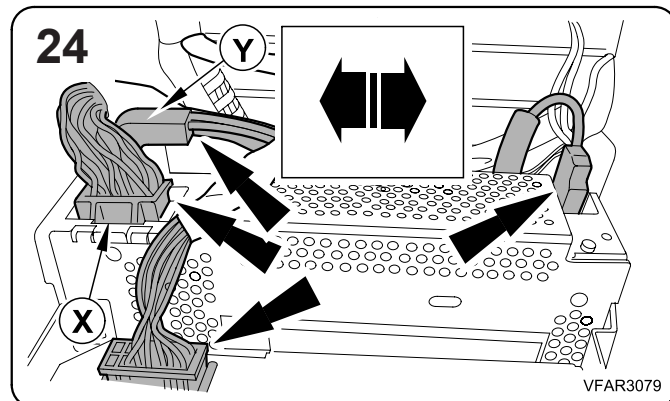
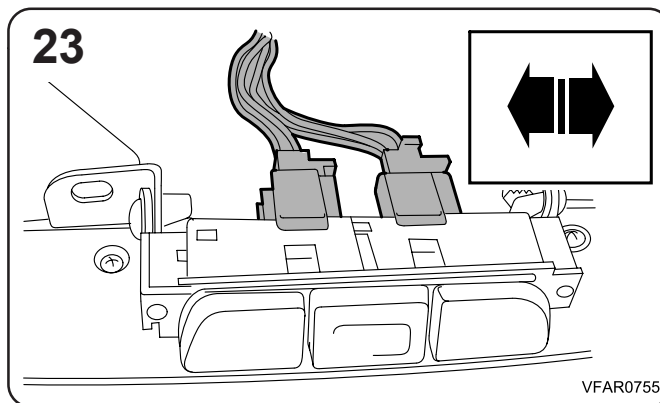
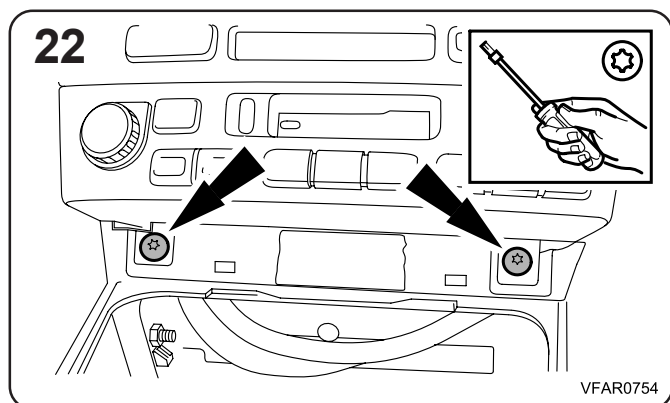
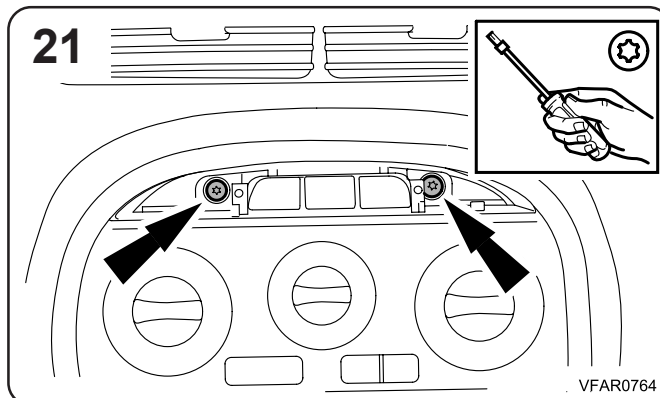
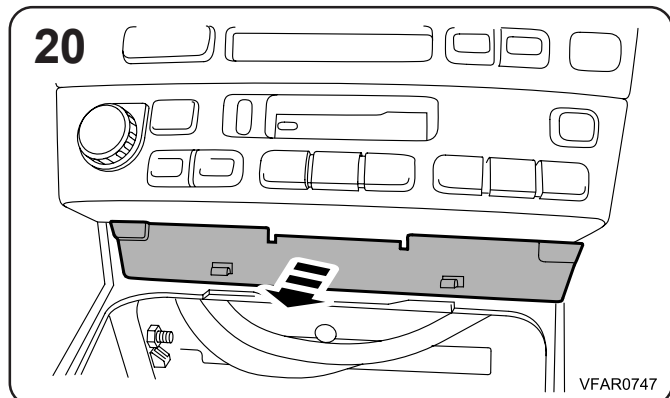

**MY 2001 →**

**Part No. C2S 46365**



**FITTING INSTRUCTIONS, INSTRUCTIONS DE MONTAGE,  
EINBAUANLEITUNG, ISTRUZIONI DI MONTAGGIO,  
INSTRUCCIONES DE MONTAJE,**

**X- Type**

**Audio Connectivity Module, Module de connectivité audio,  
Audio-anschaltmodul, Modulo per connettività avanzata,  
Módulo de conectividad de audio**

**27**

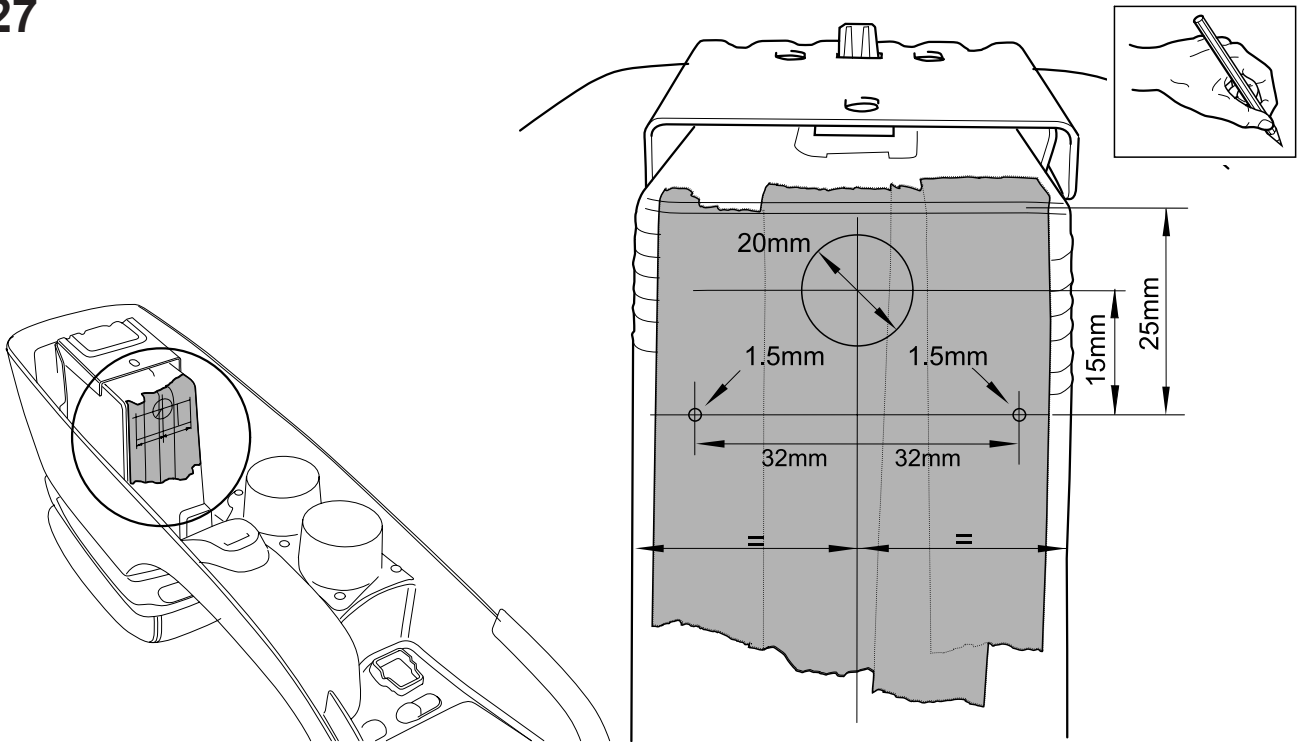

VFAG2911

**28**

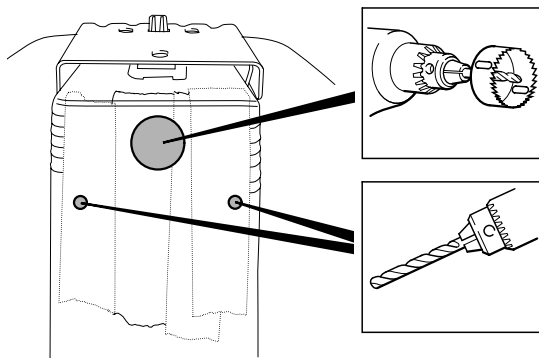

VFAG2923

**29**

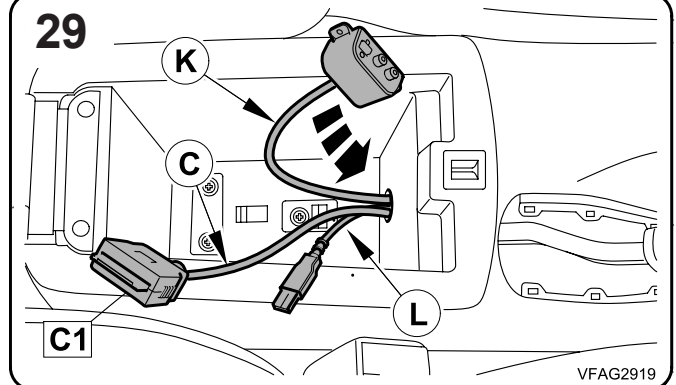

VFAG2919

**MY 2001 →**

**Part No. C2S 46365**



VFAG2991  
**FITTING INSTRUCTIONS, INSTRUCTIONS DE MONTAGE,  
EINBAUANLEITUNG, ISTRUZIONI DI MONTAGGIO,  
INSTRUCCIONES DE MOTAJE,**

**X- Type**

**Audio Connectivity Module, Module de connectivité audio,  
Audio-anschlusmodul, Modulo per connettività avanzata,  
Módulo de conectividad de audio**

**30**

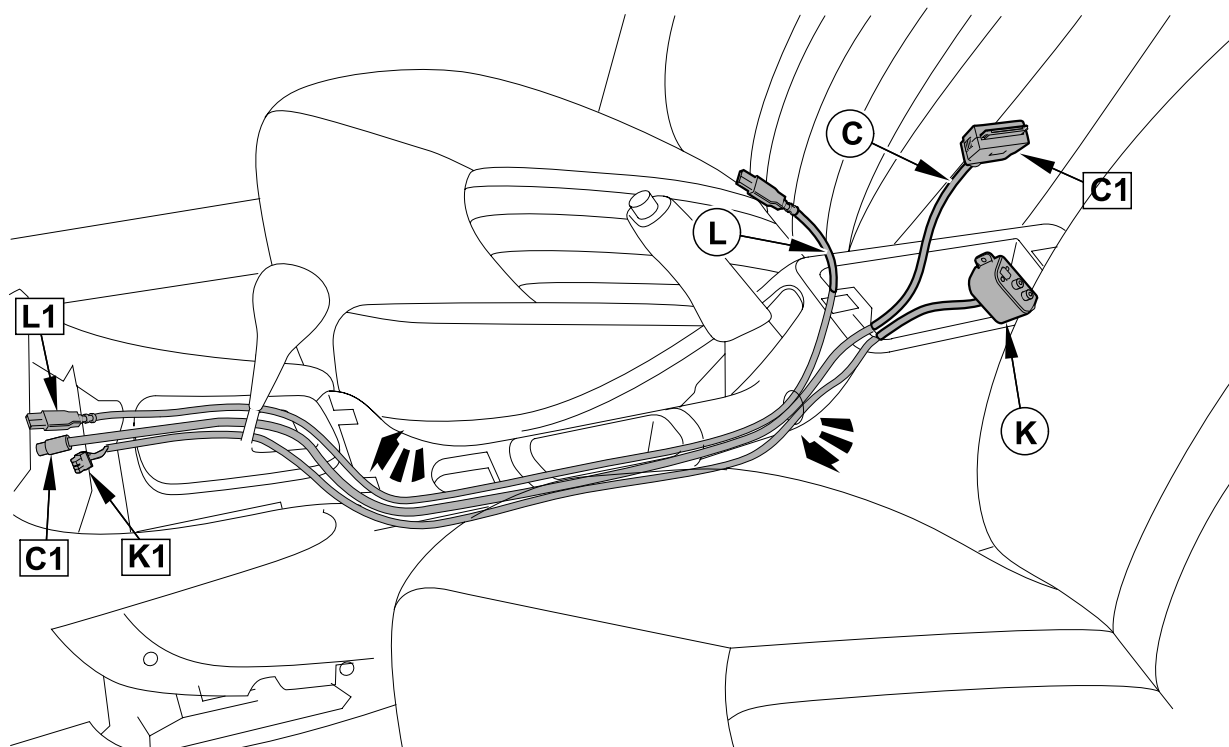

VFAG2920

**31**

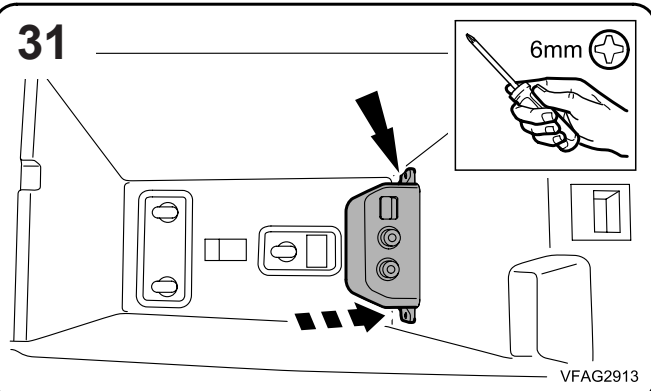

VFAG2913

**32**

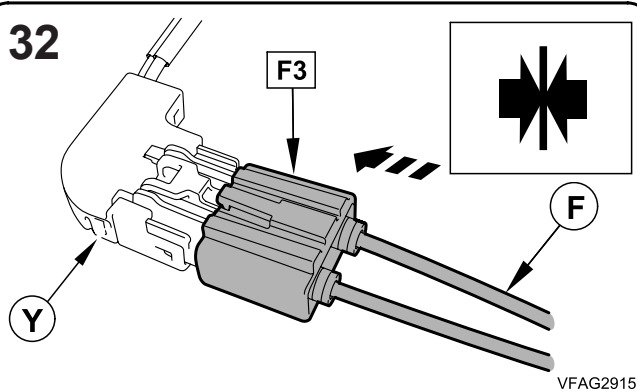

VFAG2915

**33**

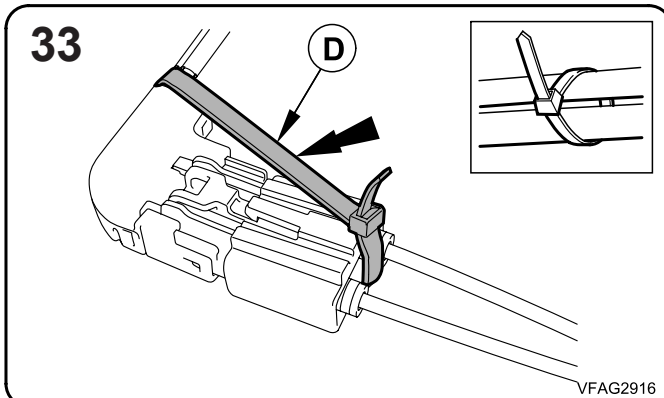

VFAG2916

**34**

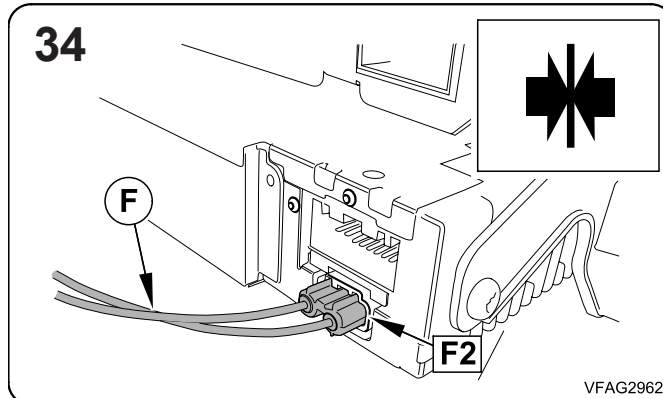

VFAG2962

**MY 2001 →**

**Part No. C2S 46365**



JAGUAR

FITTING INSTRUCTIONS, INSTRUCTIONS DE MONTAGE, EINBAUANLEITUNG, ISTRUZIONI DI MONTAGGIO, INSTRUCCIONES DE MONTAJE,

X- Type

Audio Connectivity Module, Module de connectivité audio, Audio-anschaltmodul, Modulo per connettività avanzata, Módulo de conectividad de audio

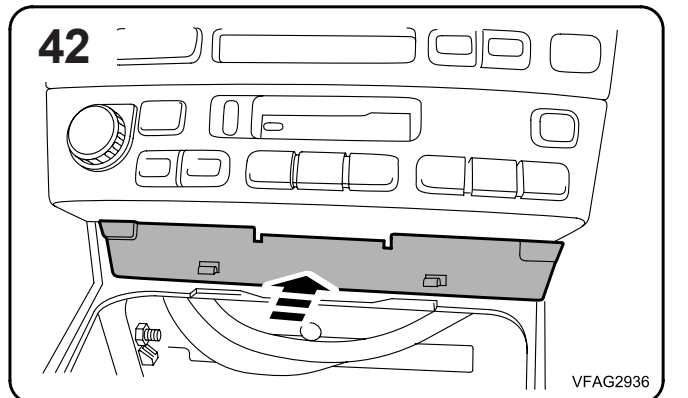
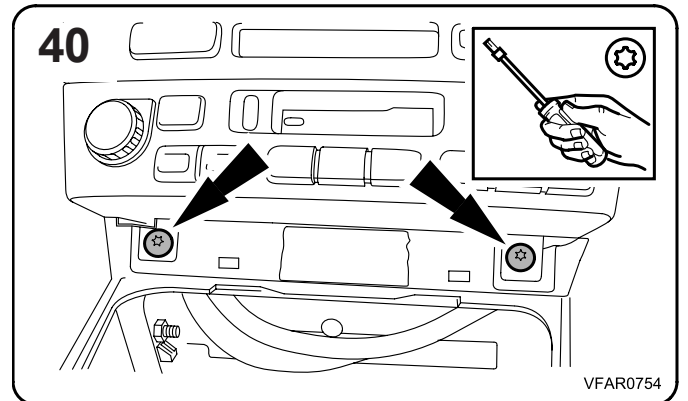
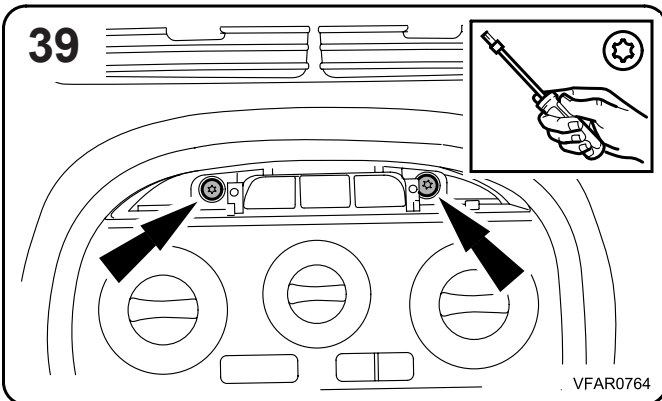
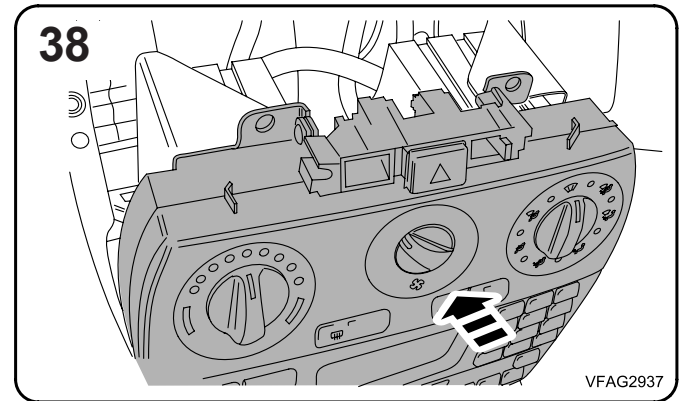
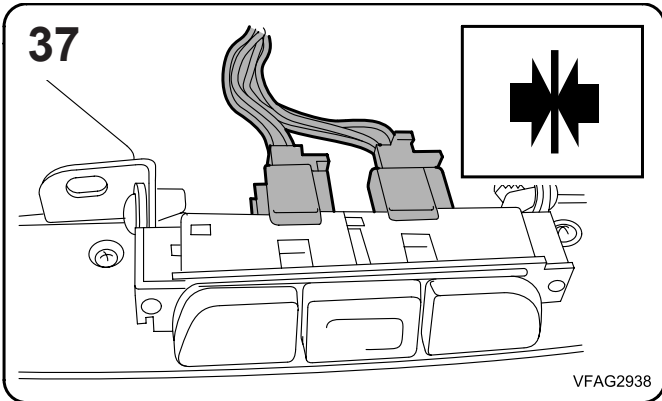
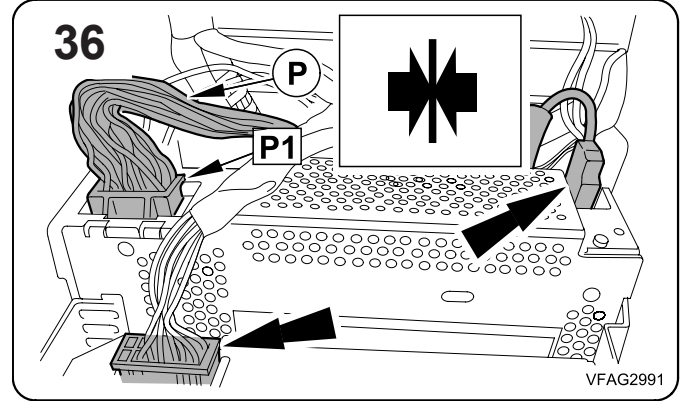
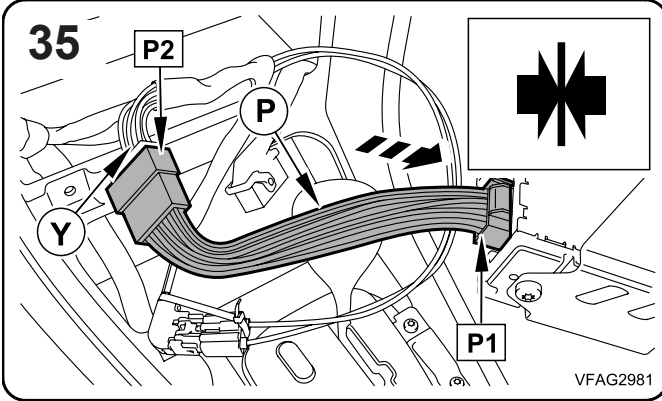

MY 2001 →

Part No. C2S 46365

**X- Type**

**Audio Connectivity Module, Module de connectivité audio,  
Audio-anschlusmodul, Modulo per connettività avanzata,  
Módulo de conectividad de audio**

**43**

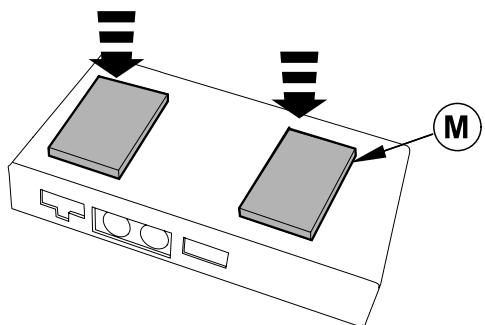

VFAG2845

**44**

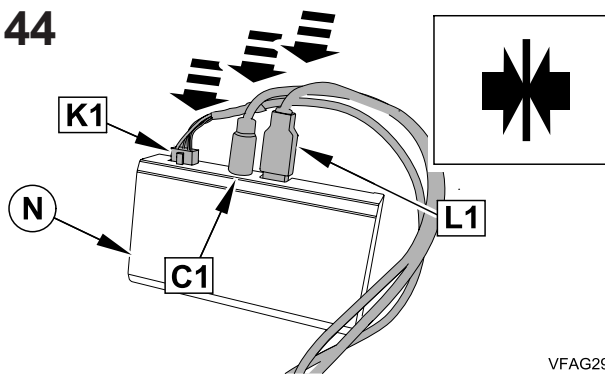

VFAG2924

**45**

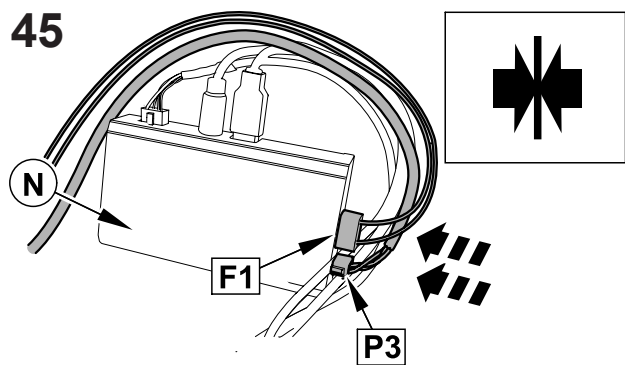

VFAG2925

**46**

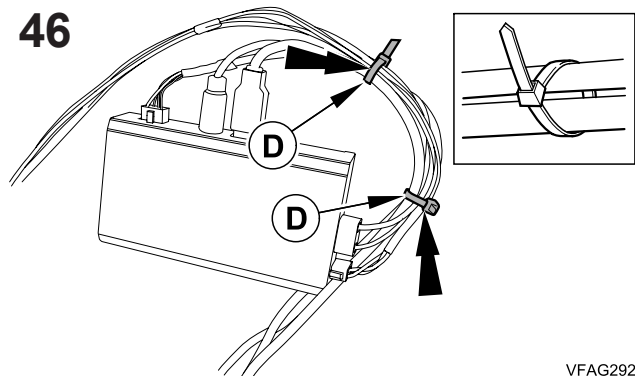

VFAG2926

**47**

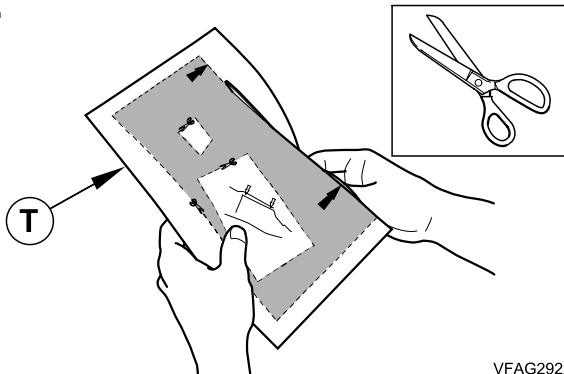

VFAG2922

**48**

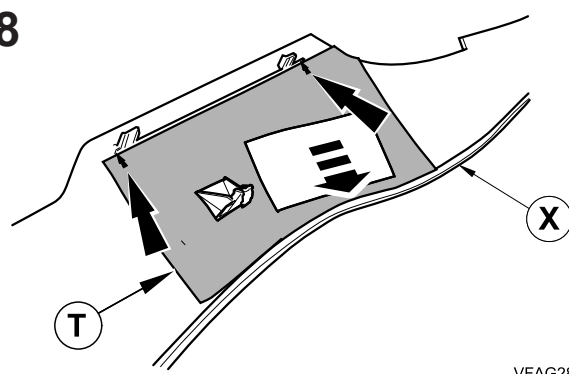

VFAG2864

**49**

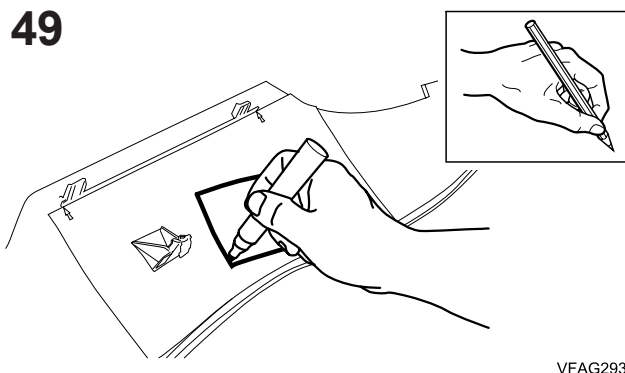

VFAG2939

**50**

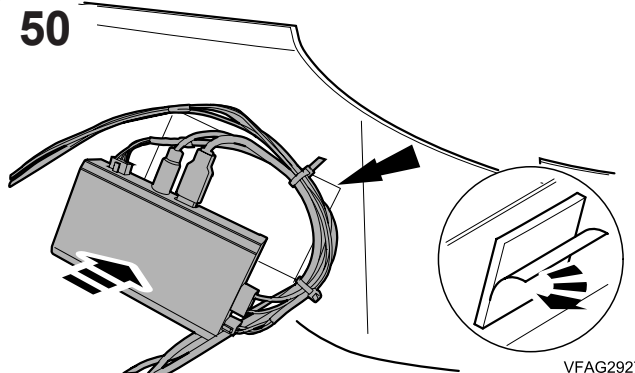

VFAG2927

**X- Type**

**Audio Connectivity Module, Module de connectivité audio,  
Audio-anschaltmodul, Modulo per connettività avanzata,  
Módulo de conectividad de audio**

**51**

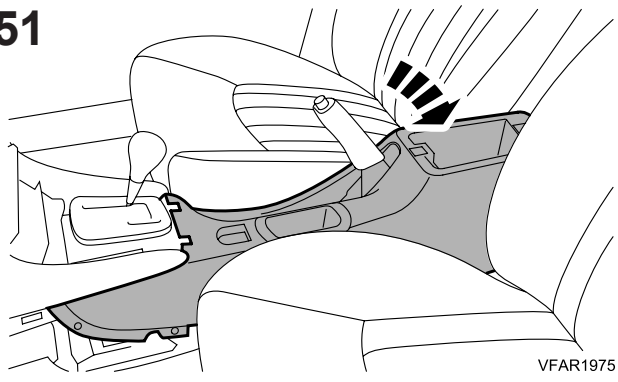

VFAR1975

**Notes: Hinweise: Note: Nota:**

- 52. Vehicles fitted with Bluetooth telephone module.
- 52. Véhicules munis d'un module de téléphone Bluetooth.
- 52. Fahrzeuge mit Bluetooth-Telefon
- 52. Vehículos equipados con módulo de teléfono Bluetooth.
- 52. Veicoli dotati di modulo telefono Bluetooth.

**52**

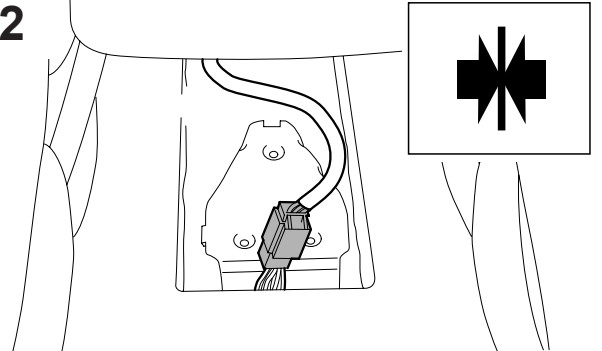

VFAR3080

**53**

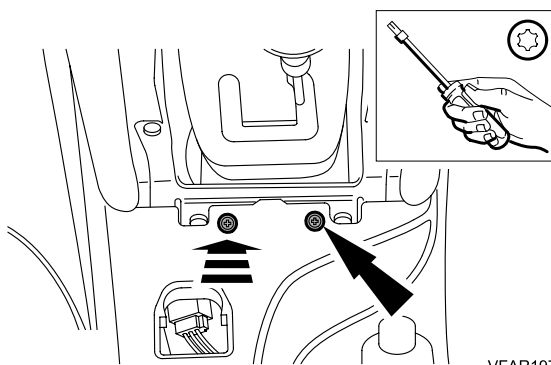

VFAR1979

**54**

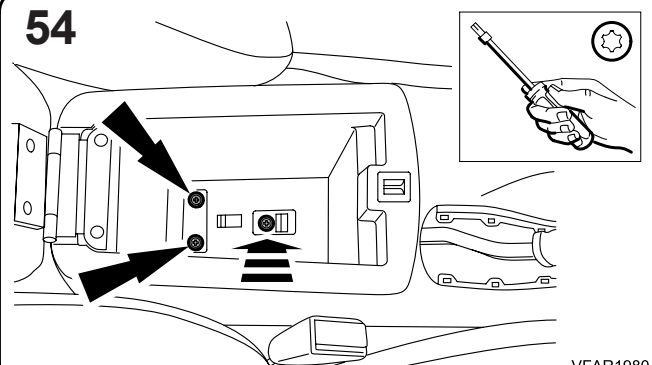

VFAR1980

**55**

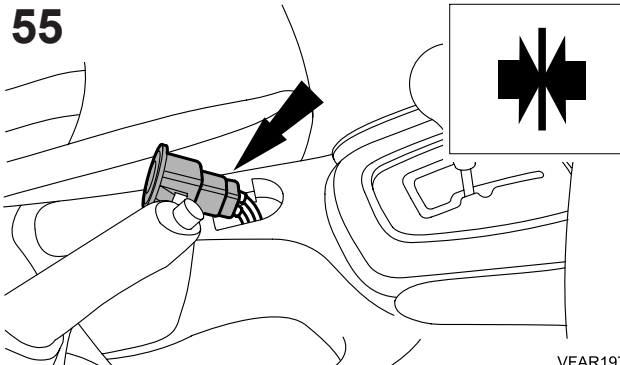

VFAR1977

**56**

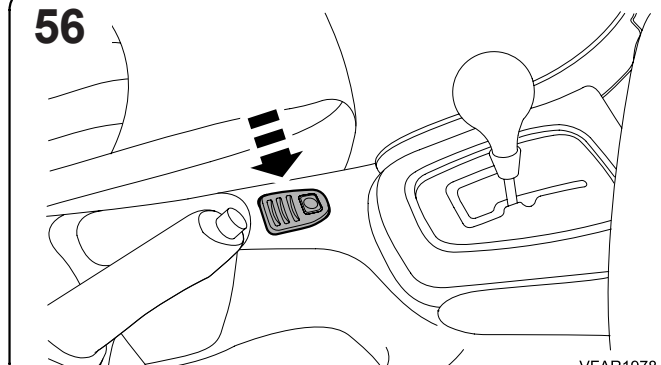

VFAR1978



**FITTING INSTRUCTIONS, INSTRUCTIONS DE MONTAGE,  
EINBAUANLEITUNG, ISTRUZIONI DI MONTAGGIO,  
INSTRUCCIONES DE MOTAJE,**

**X- Type**

**Audio Connectivity Module, Module de connectivité audio,  
Audio-anschlusmodul, Modulo per connettivita avanzata,  
Módulo de conectividad de audio**

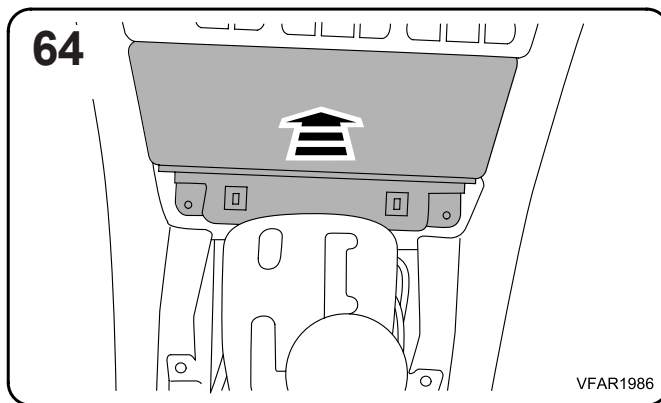
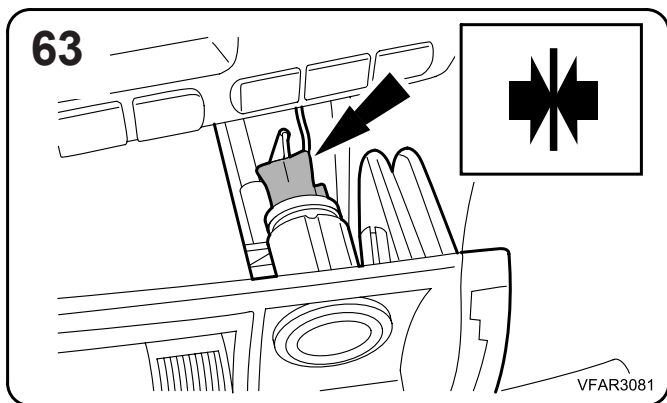
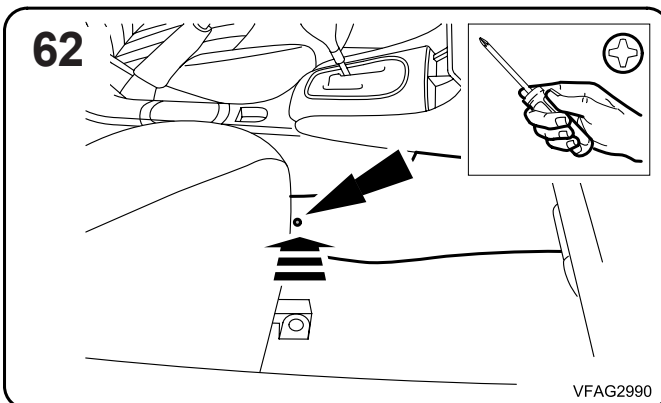
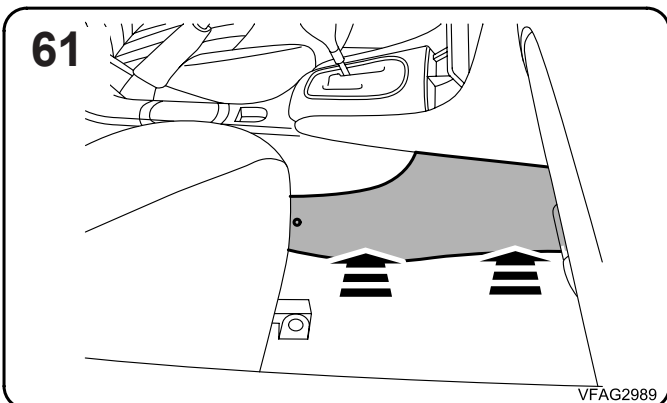
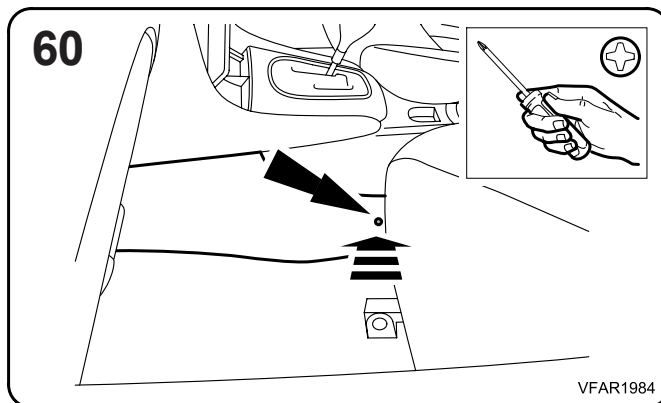
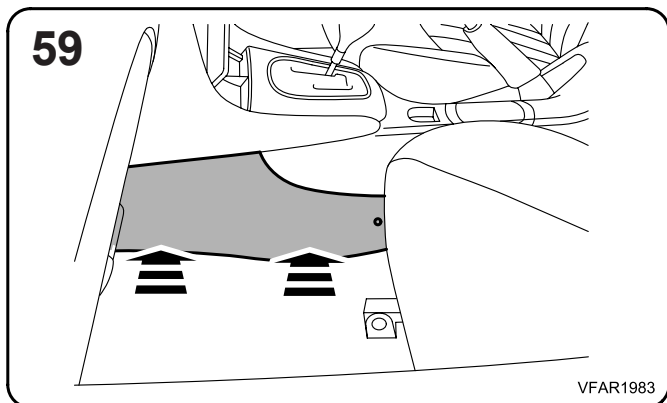
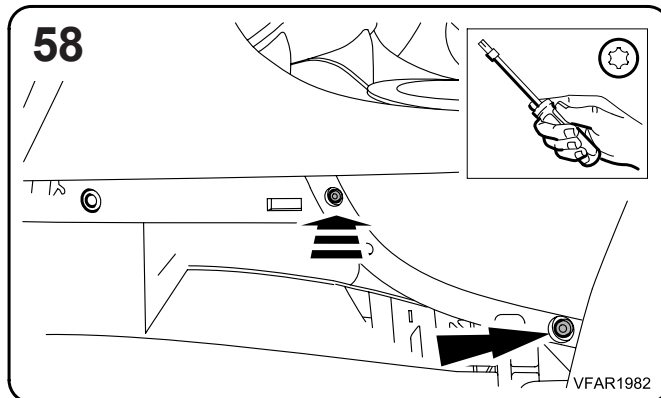
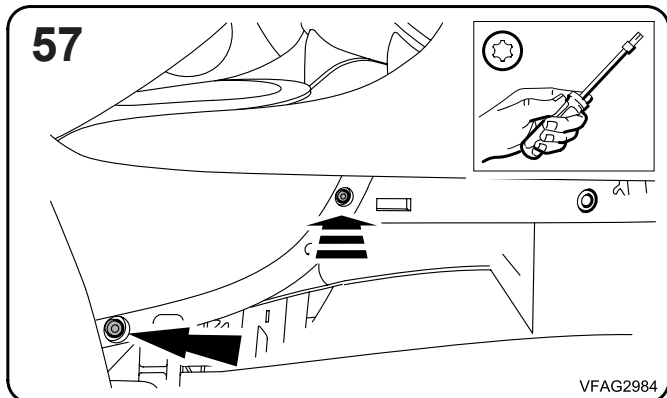

**MY 2001 →**

**Part No. C2S 46365**

**X- Type**

**Audio Connectivity Module, Module de connectivité audio,  
Audio-anschaltmodul, Modulo per connettività avanzata,  
Módulo de conectividad de audio**

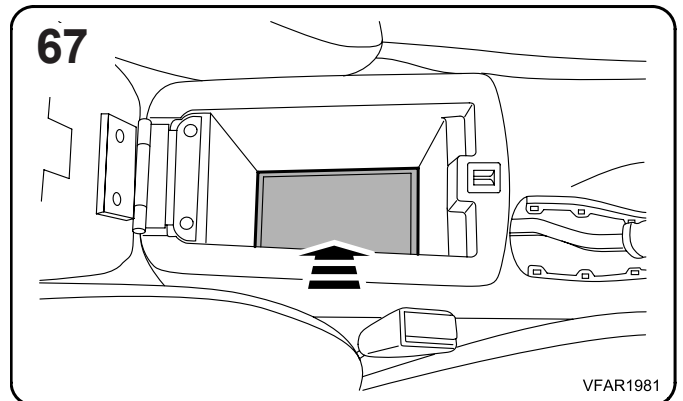
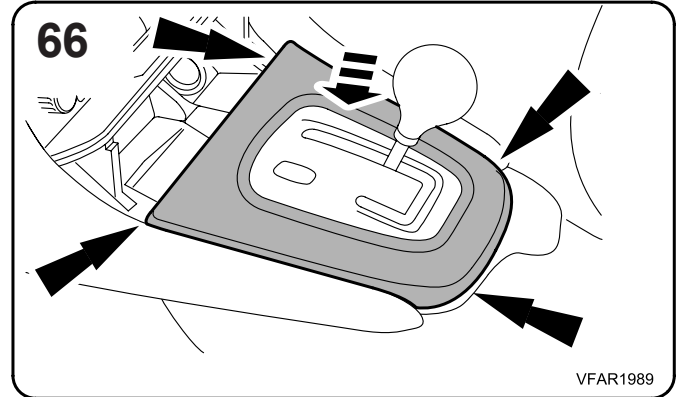
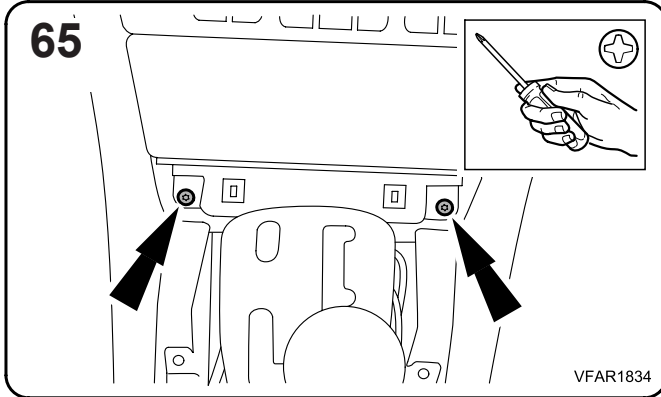

**Notes : Hinweise : Note : Nota**

- 68. Refer to GTR / Drivers Handbook to ensure correct operations are carried out, relevant to battery disconnect and reconnect.
- 68. Se reporter au GTR / Manuel de l'utilisateur pour pouvoir effectuer les opérations correctes, applicables au débranchement et au branchement de la batterie.
- 68. Zur korrekten Durchführung der Arbeitsschritte beim Ab- und Anklempfen der Batterie siehe GTR/Fahrzeug-Bedienungsanleitung.
- 68. comprobar que se realizan las operaciones correspondientes relativas a la desconexión y conexión de la batería.
- 68. Vedere il GTR / Manuale del proprietario per accertarsi di eseguire le operazioni corrette, per ciò che concerne lo scollegamento e il collegamento della batteria.

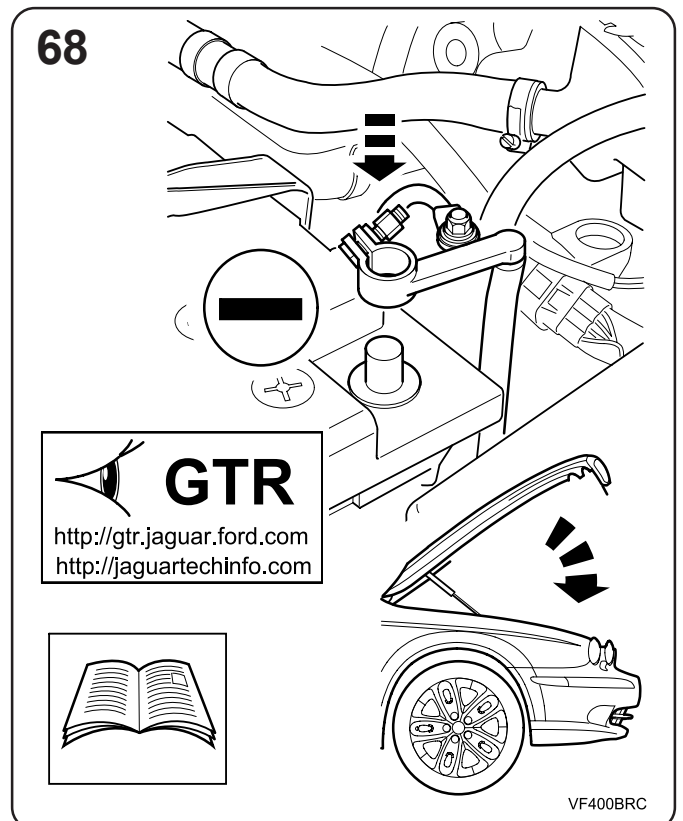



Template (T)  
Calibre (T)  
Schablone (T)  
Plantilla (T)  
Mascherina (T)

