

# Vehicle Care

---



## WARNING:

Many liquids and other substances used in vehicles are poisonous and should never be consumed and must be kept away from open wounds. These substances include antifreeze, brake fluid, fuel, windscreen washer additives, lubricants and various adhesives.

Caution: Read individual product warnings before using any car cleaning or washing products.

## CLEANING PRODUCTS



## WARNING:

Dry cleaning fluids may be toxic or flammable. Take adequate precautions when handling these products.

Brush and clean the interior regularly. Use a vacuum cleaner where possible to remove all dust from the interior and trim.

## CLEANING THE EXTERIOR

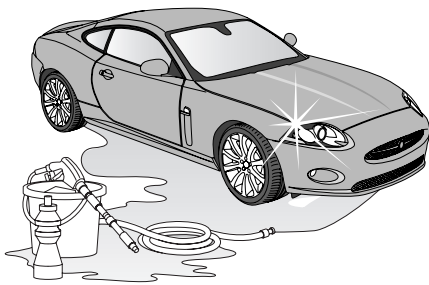

JAG0437G

### Washing your vehicle

For best results, do not wash the vehicle under strong sunlight. Always allow the vehicle to cool down before washing.

Do not use a dry cloth to wipe dirty paintwork. Dust and gritty substances are abrasive and will scratch the paintwork. Remove dirt using a cellulose sponge and plenty of warm (never hot) water. Rinse off with clean water and dry using a clean, damp chamois leather.

Do not use household soaps or detergents. The use of Jaguar Vehicle Shampoo is recommended.

### Using an automatic wash

#### Caution:

- Ensure that **AUTO**, wipers, is not selected when entering a car wash or damage to the wiper blades and arms can occur as they can operate in the car wash.
- Ensure that the audio system is turned **OFF** so that the aerial is retracted.

*Note: Regular use of automatic car washes tends to dull the lustre of the paintwork.*

After leaving the car wash, switch on the windscreen wiper immediately to remove water and prevent a build up of wax.

### Convertible top fabric

#### Caution:

- Do not use an automatic car wash that has rotating brushes. The action of the brushes may damage the exterior fabric or the seals of the convertible top.
- Do not use spot cleaners, chemical dilutants or any organic cleaners. If in doubt, contact your Jaguar Dealer/Authorised Repairer.

# Vehicle Care

---

To maintain the appearance and condition of the convertible top, the recommendations given below should be followed. This is of particular importance in the case of light coloured tops.

Do not leave the top in the open (folded) position for longer than is necessary, as in certain circumstances permanent soiling along the folds may occur.

**Cleaning:** Every 1 600 km (1 000 miles) vacuum clean and wash the convertible top using the Jaguar Soft Top Cleaning Kit, carefully following the instructions enclosed.

**Reproofing:** Every 8 000 km (5 000 miles) reproof the top using the solution in the cleaning kit, carefully following the instructions enclosed.

## Preparation for Winter

Before the onset of Winter, it is advisable to coat the convertible top seals and respective body seals with a compound, such as Carbaflo KSP 105, to aid operation in freezing conditions.

This action will need to be repeated at the start of each Winter to maintain protection.

Care must be taken so that the compound does not come into contact with the convertible top material. For further advice you should contact your Jaguar Dealer/Authorised Repairer.

## Aerial care

Regular cleaning with a special aerial cleaner, will ensure smooth and reliable operation of the aerial.

In freezing conditions check that no ice has formed over the top of the aerial, which could prevent it being raised and cause damage to the motor.

The Jaguar Aerial Cleaning Kit contains the necessary maintenance items.

## Using a high pressure washer

**Caution: Some high pressure cleaning systems are sufficiently powerful to penetrate door and window seals and damage rubbing strips and locking mechanisms. Never aim the water jet directly at heater air intakes, body seals, the convertible top, or at any component that might easily be damaged.**

When salt is used on the roads, wash the vehicle frequently, and immediately after encountering such conditions. Clean undersides and wheel arches using a high pressure jet.

## Underbonnet cleaning

**Caution: Do not use a high pressure washer or steam cleaner in the engine compartment. Damage to components could occur.**

## Glass surfaces

Clean the rear window with a soft cloth to avoid damaging the heating element. DO NOT scrape the glass or use any abrasive cleaning fluid.

Mirror glass is particularly susceptible to damage. Wash with soapy water. DO NOT use abrasive cleaning compounds or metal scrapers to remove ice.

The following products will ensure glass surfaces and windscreen wipers are kept in good condition:

Jaguar Screen Clean Paste – Apply to the exterior of the windscreen only to ensure effective operation of the windscreen wiper.

# Vehicle Care

---

Jaguar Glass Cleaner – Interior and exterior of all other glass surfaces.

Jaguar Screen Wash – Washer reservoir additive.

Jaguar Winter Care Kit comprising de-icer, ice scraper, anti-mist wipe cloth and aerial cleaner – for use in adverse weather conditions.

## Cleaning the rear screen

To avoid damaging the heating and radio elements, coupe only, when cleaning the inside of the rear screen use only a soft damp cloth or chamois leather. Do not use solvents or sharp objects to clean the glass.

## Care of alloy road wheels

The alloy road wheels are covered with a protective anti-corrosion coating. To prevent corrosion it is essential that this coating is not damaged.

When removing or fitting tyres always advise the tyre fitter to treat the alloy wheels with great care. Tyre levers must not be used.

Wash the wheels regularly with soap and water to avoid an accumulation of particles. In salty conditions the wheels should be cleaned more frequently.

Jaguar acid-free wheel cleaner can be used to remove heavy soiling. Do not use non-approved acid based cleaners should not be used.

## Removing Grease and Tar

Remove grease or tar with Jaguar Tar Remover or methylated spirit (alcohol). White spirit is also effective, but must not be applied to rubber, particularly the windscreen wiper blades.

## Bird Droppings

Do not allow bird droppings or tree sap to harden. Remove from paintwork immediately with a lukewarm soap and water solution.

## Polishing

For maximum protection against road dust, salts, industrial fall-out etc., it is recommended that the vehicle is polished regularly using Jaguar polish and a polishing cloth.

**Note:** *The vehicle's brightwork should be cleaned in the same way as the paintwork: Chrome polish or other abrasive cleaners must not be used.*

## CLEANING THE INTERIOR

**Caution:** **To prevent airbag damage, the steering wheel centre pad and other areas containing airbags should only be cleaned sparingly with a damp cloth, warm water and a non-detergent soap. Do not allow these areas to be flooded with chemical solvents, liquids, furniture cream or polishes.**

## Leather

Leather is an easy to maintain natural product, however, dust and substances can penetrate the pores and crease the leather, causing surface wear and brittleness.

To prevent ingrained dirt and staining, inspect the seat upholstery regularly and clean every one to two months as follows:

- Wipe off fine dust from the seat surfaces using a clean, damp, non-coloured cloth. Change frequently to a clean area of cloth to avoid abrasive action on the leather surface. Avoid over-wetting.

# Vehicle Care

---

- If this is not sufficient, use a cloth which has been dampened with warm soapy water and then wrung out. Use only mild non-caustic soap.
- Use Jaguar Leather Cleaner for heavily soiled areas. Dry off and rub with a clean soft cloth, changing surfaces regularly.

When staining (e.g. from clothing) or spillage occurs, clean the affected area immediately as described above.

Use Jaguar Leather Cleaner several times a year to maintain its appearance and suppleness. The cleaner will nourish and moisturise and help to improve the surface protective film against dust and substances.

- Do not use solvents. Do not use detergents, furniture polish or household cleaners. While these products may initially give impressive results, their use will lead to rapid deterioration of the leather and will invalidate the warranty. Jaguar recommend a basic set of products that have been specially selected for the type of leather in your vehicle.
- Dark clothing may stain leather seats just like other upholstery products.
- Sharp objects such as belts, zip fasteners, rivets, etc. can leave permanent scratches and scratch marks on the leather surface.
- Unless spillages such as tea, coffee or ink are washed away immediately, permanent staining may have to be accepted.

If a valet service is used, ensure that the specialist concerned is aware of, and follows these instructions precisely.

## Cloth and fabric

### Caution:

- **Never use soap, ammonia, bleach or other cleaners intended for use on hard surfaces.**
- **Do not use upholstery cleaner on electrical equipment such as facia switches.**
- **When cleaning around electrical equipment such as switches, ensure that fluids do not leak into any gaps around the components or between panels or trim.**

Use Jaguar Upholstery Cleaner, following the instructions. Do not over wet.

## Removing stains

Most stains on woollen fabric can be removed if treatment is carried out immediately, before the stain has a chance to dry-in.

Most stains can be treated with one of three cleaning fluids: Jaguar Upholstery Cleaner, dry cleaning fluid or clean water. Follow the instructions on the package.

## Carpet and mats

Marks or stains can be removed by gentle scrubbing with a weak solution of soap and warm water.

For more stubborn stains a commercially available carpet cleaner should be used.

# Vehicle Care

---

## Floor mat retention

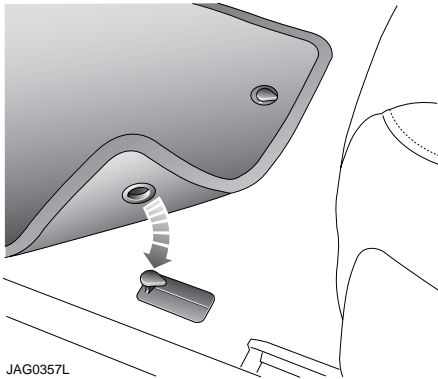

The driver's floor mat is correctly must be correctly positioned and secured under the tongues on the retention posts (only one post shown). Ensure that the mat does not interfere with the operation of the accelerator or brake pedal.

## REPAIRING MINOR PAINT DAMAGE

### Paint Chips

Scratches and chips should be touched in before weathering action begins. Inspect the paintwork immediately after the vehicle has been washed.