

Vehicle care

CLEANING PRODUCTS

WARNINGS



Many liquids and other substances used in vehicles are poisonous and should never be consumed and must be kept away from open wounds.

These substances include antifreeze, brake fluid, fuel, windscreen washer additives, lubricants and various adhesives.



Dry cleaning fluids may be toxic or flammable. Take adequate precautions when handling these products.

CAUTION



Read individual product warnings before using any vehicle cleaning or washing products.

Brush and clean the interior regularly. Use a vacuum cleaner where possible to remove all dust from the interior and trim.

CLEANING THE EXTERIOR



E91586

CAUTIONS



Some high pressure cleaning systems are sufficiently powerful to penetrate door and window seals, and damage trim and door locks. Never aim the water jet directly at the engine air intake, heater air intakes, body seals (doors, sunroof, windows etc.) or at any components which may be damaged (lamps, mirrors, exterior trim etc).



Ensure that you read and comply with all warnings and instructions supplied with any cleaning products.



Never use cleaning products which are not approved for use on vehicles.

Vehicle care

Washing the vehicle

CAUTION

 Substances which are corrosive, such as bird droppings, tree resin, dead insects, tar spots, road salt and industrial fall out, can damage the vehicle's paintwork. Any such deposits should be removed as soon as possible, to prevent damage to the vehicle's paintwork.

Remove heavy deposits of mud and dirt with a hose, before washing the vehicle.

When salt is used on the roads, wash the vehicle immediately after encountering such conditions. Clean undersides and wheel arches using a high pressure jet.

Wash the vehicle frequently. Do not use a dry cloth to wipe dirty paintwork. Dust and gritty substances are abrasive and will scratch the paintwork. Remove dirt using a cellulose sponge and generous quantities of cold or luke warm (never hot) water containing a suitable car shampoo. Rinse thoroughly with clean water and dry with a clean, damp chamois leather or synthetic substitute.

For best results, do not wash the vehicle under strong sunlight. Always allow the vehicle to cool down before washing.

Do not use household soaps or detergents. The use of Jaguar Vehicle Shampoo is recommended.

Using an automatic wash

CAUTION

 Ensure that AUTO wipe is not selected when entering a car wash or damage to the wiper blades and arms can occur as they will operate in the car wash.

Note: *Regular use of automatic car washes tends to dull the lustre of the paintwork.*

After leaving the car wash, switch on the windscreen wiper immediately, to remove water and prevent a build up of wax.

Convertible top fabric

CAUTIONS

 Do not use an automatic car wash that has rotating brushes. The action of the brushes may damage the exterior fabric or the seals of the convertible top.

 Do not use spot cleaners, chemical dilutants or any organic cleaners. If in doubt, contact your Jaguar Dealer/ Authorised Repairer.

To maintain the appearance and condition of the convertible top, the recommendations given below should be followed. This is of particular importance in the case of light coloured tops.

Do not leave the top in the open (folded) position for longer than is necessary, as in certain circumstances permanent soiling along the folds may occur.

Cleaning: Every 1 600 km (1 000 miles) vacuum clean and wash the convertible top using the Jaguar Soft Top Cleaning Kit, carefully following the instructions enclosed.

Reproofing: Every 8 000 km (5 000 miles) reproof the top using the solution in the cleaning kit, carefully following the instructions enclosed.

Vehicle care

Underbonnet cleaning

CAUTION



Do not use a high pressure washer or steam cleaner in the engine compartment. Damage to components could occur.

Preparation for winter

Before the onset of winter, it is advisable to coat the convertible top seals and respective body seals with a compound, such as Carbaflo KSP 105, to aid operation in freezing conditions. This action will need to be repeated at the start of each winter to maintain protection.

Care must be taken so that the compound does not come into contact with the convertible top material. For further advice you should contact your Jaguar Dealer/Authorised Repairer.

Glass surfaces

Clean the rear window with a soft cloth to avoid damaging the heating element. Do not scrape the glass or use any abrasive cleaning fluid.

Mirror glass is particularly susceptible to damage. Wash with soapy water. Do not use abrasive cleaning compounds or metal scrapers to remove ice.

The following products will ensure glass surfaces and windscreen wipers are kept in good condition:

Jaguar Screen Clean Paste: Apply to the exterior of the windscreen only to ensure effective operation of the windscreen wiper.

Jaguar Glass Cleaner: Interior and exterior of all other glass surfaces.

Jaguar Screen Wash: Washer reservoir additive.

Jaguar Winter Care Kit: Comprising de-icer, ice scraper and anti-mist wipe cloth.

Cleaning the rear screen

To avoid damaging the heating and radio elements (coupe only), when cleaning the inside of the rear screen use only a soft damp cloth or chamois leather. Do not use solvents or sharp objects to clean the glass.

Removing grease and tar

Remove grease or tar with Jaguar Tar Remover or methylated spirit (alcohol). White spirit is also effective, but must not be applied to rubber, particularly the windscreen wiper blades.

Bird droppings

Do not allow bird droppings or tree sap to harden. Remove from paintwork immediately with a lukewarm soap and water solution.

Polishing

For maximum protection against road dust, salts, industrial fall-out etc., it is recommended that the vehicle is polished regularly using Jaguar polish and a polishing cloth.

Note: *The vehicle's brightwork should be cleaned in the same way as the paintwork: Chrome polish or other abrasive cleaners must not be used.*

Vehicle care

CLEANING THE INTERIOR

WARNING



Ensure that you read all of the information and instructions for use provided with cleaning products.

Some products contain substances that are harmful and can cause health problems if used incorrectly.

CAUTIONS



Some products, if used incorrectly can cause damage to the interior surfaces of the vehicle.



To prevent airbag damage, the steering wheel centre pad and other areas containing airbags should only be cleaned sparingly with a damp cloth, warm water and a non-detergent soap. Do not allow these areas to be flooded with chemical solvents, liquids, furniture cream or polishes.

Leather

Leather is easy to maintain, however, dust and substances can penetrate the pores and crease the leather, causing surface wear and brittleness.

To prevent ingrained dirt and staining, inspect the seat upholstery regularly and clean every one to two months as follows:

- Wipe off fine dust from the seat surfaces using a clean, damp, non-coloured cloth. Change frequently to a clean area of cloth to avoid abrasive action on the leather surface. Avoid over-wetting.
- If this is not sufficient, use a cloth which has been dampened with warm soapy water and then wrung out. Use only mild non-caustic soap.
- Use Jaguar Leather Cleaner for heavily soiled areas. Dry off and rub with a clean soft cloth, changing surfaces regularly.

When staining (e.g. from clothing) or spillage occurs, clean the affected area immediately as described above.

Use Jaguar Leather Cleaner several times a year to maintain its appearance and suppleness. The cleaner will nourish and moisturise and help to improve the surface protective film against dust and substances.

- Do not use solvents. Do not use detergents, furniture polish or household cleaners. While these products may initially give impressive results, their use will lead to rapid deterioration of the leather and will invalidate the warranty. Jaguar recommend a basic set of products that have been specially selected for the type of leather in your vehicle.
- Dark clothing may stain leather seats just like other upholstery products.
- Sharp objects such as belts, zip fasteners, rivets, etc. can leave permanent scratches and scratch marks on the leather surface.
- Unless spillages such as tea, coffee or ink are washed away immediately, permanent staining may have to be accepted.

If a valet service is used, ensure that the specialist concerned is aware of, and follows these instructions precisely.

Vehicle care

Cloth and fabric

CAUTIONS

- ⚠ Never use soap, ammonia, bleach or other cleaners intended for use on hard surfaces.
- ⚠ Do not use upholstery cleaner on electrical equipment, such as facia switches.
- ⚠ When cleaning around electrical equipment such as switches, ensure that fluids do not leak into any gaps around the components or between panels or trim.

Use Jaguar Upholstery Cleaner, following the instructions. Avoid over-wetting.

Removing stains

Most stains on woollen fabric can be removed if treatment is carried out immediately, before the stain has a chance to dry-in.

Most stains can be treated with one of three cleaning fluids: Jaguar Upholstery Cleaner, dry cleaning fluid or clean water. Follow the instructions on the package.

Instrument pack, clock, and audio equipment

Only use a soft dry cloth to clean the instrument pack, clock, and audio equipment. Do not use cleaning fluids or sprays.

Carpet and mats

Marks or stains can be removed by gentle scrubbing, with a weak solution of soap and warm water.

For more stubborn stains, a commercially available carpet cleaner should be used.

Floor mat retention

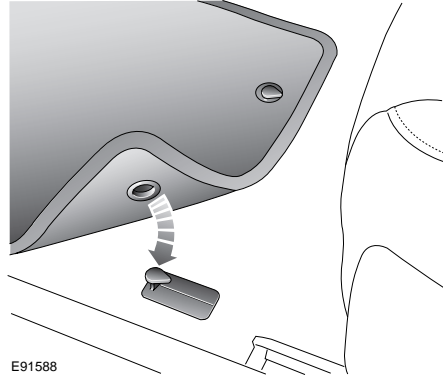

The driver's floor mat must be correctly positioned and secured under the tongues on the retention posts (only one post shown). Ensure that the mat does not interfere with the operation of the accelerator or brake pedal.

Seat belts

WARNING



Do not allow any water, cleaning products or fabric from cloths to enter the seat belt mechanism. Any substance which enters the mechanism, may affect the performance of the seat belt in an impact.

Extend the seat belts fully, then use warm water and a non-detergent soap to clean. Allow the seat belts to dry naturally while fully extended.

Note: When cleaning the seat belt, take the opportunity to examine the webbing for damage and wear. Any wear or damage should be reported to, and rectified by, a Jaguar Dealer/Approved Repairer.

CLEANING ALLOY WHEELS

CAUTION



Do not use non-approved, or acid based wheel cleaners. These can damage the wheel coating which may lead to corrosion of the wheel rims.

The alloy road wheels are covered with a protective anti-corrosion coating. To prevent corrosion, it is essential that this coating is not damaged.

When removing or fitting tyres, always advise the tyre fitter to treat the alloy wheels with great care. Tyre levers must not be used.

Wash the wheels regularly with soap and water, to avoid an accumulation of particles. In salty conditions, the wheels should be cleaned more frequently.

Jaguar acid-free wheel cleaner can be used to remove heavy soiling.

REPAIRING MINOR PAINT DAMAGE

Regularly inspect the paintwork for damage. Inspect the paintwork immediately after the vehicle has been washed. Any stone chips, fractures or deep scratches in the paint or bodywork, should be repaired promptly. Bare metal will corrode quickly and if left untreated, can result in expensive repairs.

Minor chips and scratches can be touched up using materials and advice available from a Jaguar Dealer/Authorised Repairer. Larger areas of damage will require professional repair and you should consult a Jaguar Dealer/Authorised Repairer.