

Engine coolant temperature (E)

Indicates the temperature of the engine coolant.

Drive at moderate road and engine speeds until normal operating temperature is reached. This is indicated when the pointer is between the blue (cold) segment and the red (hot) segment.

The engine operating temperature will vary with changes in weather and engine load. The engine temperature may rise in some circumstances, such as:

- Idling for long periods in slow moving traffic.
- Driving up a long hill in hot weather.
- Driving slowly or stopping after driving at high speed.

Should the pointer move into the red segment (H), stop the vehicle as soon as it is safely possible and allow the engine to cool. Switching off the climate control system may assist engine cooling.



WARNING:
Do not remove the pressure cap from the coolant expansion tank filler while the engine is hot.

Instruments

None of the instruments will show correct indications until the ignition is switched ON (position 'II').

If the exterior light switch is ON the display brightness can be varied using the dimmer switch (see page 4-7).

Tachometer (A)

The tachometer indicates engine speed in revolutions per minute and is calibrated in increments of 500 extending to 7500 rev/min.

Speedometer (B)

Speed indication is in either:

USA – miles per hour, the outer figures, and kilometres per hour on the inner ring.

Canada and Mexico – kilometres per hour, the outer figures, and miles per hour on the inner ring.

Odometer (C)

Records the total distance covered by the vehicle.

Fuel level gauge (D)

Indicates the amount of fuel in the tank. The gauge works only with the ignition ON and in position 'II'. A warning light indicates when the remaining fuel has fallen to approximately 2.6 US gallons (10 litres).

4-2 On the road

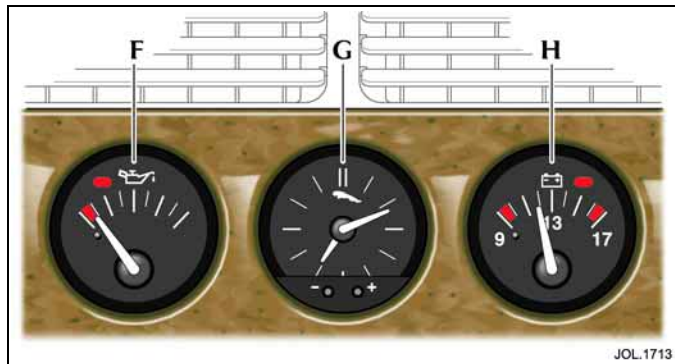

The following gauges are situated on the fascia panel above the centre console.

Note: If a navigation system is fitted the gauges will no longer be part of the fascia and tell-tale lights on the instrument cluster will give indication of battery or oil pressure status.

The clock will displayed on the navigation screen when the system is switched on. To adjust the clock, please refer to the Navigation Handbook.

Oil pressure gauge (F)

Indicates the engine oil pressure, not the level of oil in the engine.

Caution: If the needle falls into the red segment, stop the vehicle as soon as it is safely possible and investigate the cause.

Clock (G)

The analogue clock can be adjusted by pressing the (+) and (-) buttons on the front of the dial. Pressing and holding either button will increase the rate of hand movement forwards or backwards as required.

Battery condition indicator (H)

Indicates the charge condition of the battery.

With the ignition in position 'II' and the engine not running, the pointer should be between 9 and 13 volts. If it is in the low red sector, the battery and/or charging system requires attention.

When the engine is running, above idle speed, the pointer should be between 13 and 17 volts. If the pointer is in the high red sector, the charging rate is too high and the cause must be investigated.

Warning lamps

A number of warning lamps are arranged within the dials of the two instrumentation clusters.

RED warning lamps are for primary warnings. AMBER warning lamps are for secondary warnings. Lighting and direction indicator warning lamps are BLUE or GREEN.

When activated, some warning lamps have associated messages displayed on the message centre, as shown in the table starting on page 4-8.

Lamp check

A lamp check cycle is initiated when the ignition is switched ON and lasts for three to four seconds (excepting the airbag warning lamp which will remain on for 5 seconds). The CHECK ENG and LOW OIL PRESSURE warning lamps stay on until the engine is running. If any warning lamp remains on after this period, investigate the cause before driving.

Not all lamps are included in the lamp check, for example main beam headlamps or direction indicators.



Low oil pressure

This lights up with the ignition switched ON and will stay on until the engine is running.

If the warning light stays ON when the engine is running, loss of oil pressure is indicated. STOP the engine immediately and investigate the cause.

Caution: Do not restart the engine until the cause of loss of oil pressure has been identified and rectified.

First check the engine oil level, see Section 7.



Adaptive cruise control

If adaptive cruise control is active, lights up to indicate that the vehicle is in 'follow mode' and automatically maintaining the desired gap to the vehicle immediately ahead.

Only applicable to vehicles fitted with adaptive cruise control.



Charge indicator

Lights up when the ignition is ON and should go out when the engine is running.

If the light stays ON when the engine is running it indicates that there is either a battery voltage fault or an alternator fault.

Turn OFF all electrical accessories, radio, climate control, rear screen heater etc. Try to use the minimum electrical load as possible such as power windows, electric sunroof etc.

Report the fault to a Jaguar Dealer.



Check engine

Lights up when the ignition is switched ON and remains on until the engine is started.

4-4 On the road



Brake

Lights up when:

- The ignition is ON and the parkbrake is ON.
- And/or the brake fluid is low.
- If the light is ON with the parkbrake NOT applied, low brake fluid is indicated. In this case, loss of braking assistance in either or both brake circuits may be imminent.



WARNING:

DO NOT drive the vehicle until the fault is rectified. Consult a Jaguar Dealer immediately.



Anti-lock braking system (ABS)

If a fault has been detected in the anti-lock brake system (ABS) this light will illuminate. The brake system will continue to function normally, but without ABS braking.

Should the light come on or stay on after the bulb check cycle, stop the vehicle at the first opportunity, turn the engine OFF and then restart.

If the ABS light comes on again, the vehicle should be driven to a Jaguar Dealer at the earliest opportunity.



Airbag

When the ignition switch is turned to position 'II', the warning lights come ON for 5 seconds.

If the airbag system develops a fault, the warning light will flash and then come ON and remain on until the fault has been diagnosed and cleared.

Report the fault to a Jaguar Dealer immediately.

It is safe to drive the vehicle; however, in an accident the airbags may not operate.



Main beam

Illuminates when the main beam headlamps are switched ON or flashed ON.



Sidelights

Lights up when the sidelights are switched ON.



Direction indicators

The appropriate indicator tell-tale will flash when the column switch is moved up or down to signal a right or left-hand turn. If a direction indicator fails, the tell-tale will flash at twice normal rate when that indicator is selected. Fit a new bulb immediately.

If a bulb has failed, the audible ticking will sound at twice the normal rate.

Hazard warning lamps

When the hazard warning is selected, both direction indicator tell-tales flash simultaneously.



High coolant temperature

Lights up if the engine coolant temperature becomes too high (gauge pointer in the red segment). It is unsafe to run the engine with the coolant temperature overheated.

If the light comes ON, stop the vehicle and switch the engine OFF. Allow the engine to cool. Report the fault to a Jaguar Dealer.



WARNING:

Do not attempt to remove the pressure cap from the coolant expansion tank until the engine is cool.



Seat belt

Lights up for 6 seconds when the ignition is switched ON and the driver's seat belt is not fastened. An audible warning sounds for 6 seconds.

Ensure seat belts are fastened before driving. If the warning light stays ON with the seat belt fastened, report the fault to a Jaguar Dealer. It is safe to drive the vehicle with the light ON, provided that the seat belts are properly fastened.



Low fuel level

Lights up to indicate low fuel level. This warning light is additional to the fuel level gauge and will come ON when the fuel has fallen to approximately 2.6 US gallons (10 litres).

4-6 On the road

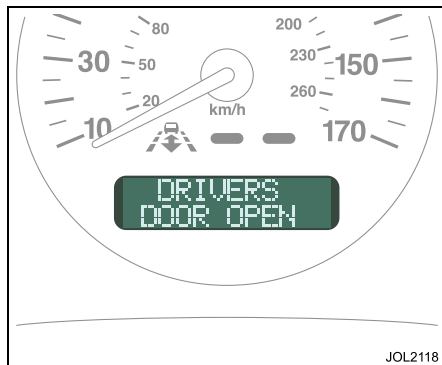

Message centre

Driver information, messages, and data are displayed on the message centre display panel situated within the speedometer.

The message centre has three functions. These are:

1. **Odometer:** Displays the total distance covered by the vehicle.
2. **Trip computer:** Displays information on the vehicle's average speed, fuel usage and range.
3. **Warning and information messages:** Displays status messages or warning messages if system faults are detected.

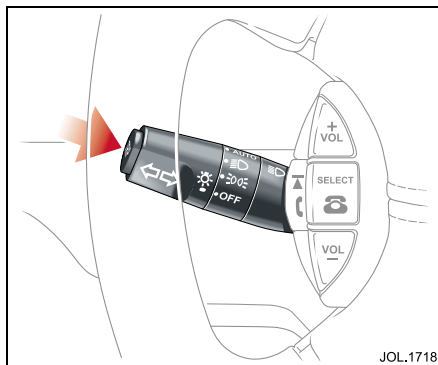

Selecting message centre functions

Message centre functions are selected by repeatedly pressing the trip function button on the left-hand column switch. The first press will switch from the odometer reading to the trip computer. Further presses will cycle through the trip computer data in sequence, until the odometer reading is displayed again.

Messages take priority over the odometer reading or trip computer data and, if active, will be displayed when the ignition is switched ON.

Odometer

When the ignition is switched ON the message centre displays the odometer reading.

The odometer will also be displayed if the ignition is in position '0' and the interior lights are ON.

The odometer reading is displayed in kilometres.

Warning and information messages

The message centre will display warning or information messages to the driver when the ignition is in position 'II'.

Most messages, when displayed, have an associated priority indicator lamp above the display which will come on to indicate the message priority:

Red lamp: Priority message

Amber lamp: Secondary message.



WARNING:

If a red warning lamp is displayed, stop the vehicle, or take appropriate action, as soon as possible.

A priority message must be investigated immediately by the driver or a Jaguar Dealer.

If more than one message is active, each is displayed in turn for 2 seconds in order of priority.

Clearing messages

Messages can be hidden by pressing CLEAR on the trip computer switchpack. One press will hide one message. Once all messages have been hidden, the display will show trip data, a further press will display the odometer reading. If CLEAR is pressed again all active messages will be re-displayed. Repeatedly pressing the CLEAR button will cycle through the trip odometer and message modes.

Hidden messages reappear after the ignition is switched OFF and ON again, if the fault remains.

If a fault occurs when in trip computer or odometer mode, the relevant message will be displayed immediately.

If a trip computer function is selected by pressing the function button while messages are displayed, the trip data will be displayed for 10 seconds, then the message will reappear.

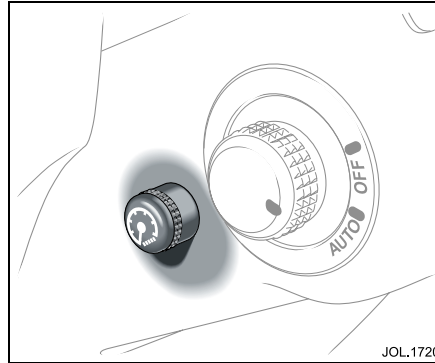

Instrument illumination and dimmer switch

With the ignition switch in position 'II', the instruments, message centre, climate control and sound system displays will be illuminated. When the exterior lighting is switched ON, the instruments, message centre and roof console amber light may be dimmed by means of the dimmer switch. The climate control panel and radio will be illuminated at a low level. If the dimmer switch is set to the 'override' position, the instruments, message centre, climate control and audio system displays, will be illuminated at maximum brightness. Warning light brightness is not affected by the dimmer switch.

To operate: Rotate the knob to adjust the illumination to the required level. To select 'override', turn the knob fully anti-clockwise.

Message centre illumination

The message centre is illuminated at all times when the ignition is ON. The illumination level can be adjusted by the dimmer switch.

4-8 On the road

Messages

Message	Priority Indicator	Meaning
SYSTEM CHECK	Both	Instruments self check immediately after ignition ON and language selection.
ENGINE STALLED	Red	Engine speed has dropped below 10 rev/min.
ENGINE COOLANT LOW	Red	Check the level in the coolant reservoir. Check temperature gauge often.
DRIVERS DOOR OPEN	Red	Check that the driver's door is closed before driving.
PASSENGERS DOOR OPEN	Red	Check that the passenger's door is closed before driving.
CONVERTIBLE NOT LATCHED	Red	Check that the convertible top is closed and locked.
DSC	Amber	DSC (Dynamic Stability Control) is operating.
DSC SYSTEM FAULT	Amber	Report the fault to a Jaguar Dealer. The vehicle may still be driven.
DSC SYSTEM ON (or OFF)	None	DSC has been turned on (or off). This message is displayed for a maximum of 4 seconds.
LIGHTS ARE OFF	None	If autolamps are fitted, exterior light switch is off, this message informs the driver that the exterior ambient light is low enough for the exterior lamps to be on if autolamps were active.

Message	Priority Indicator	Meaning
ENGINE SYSTEM FAULT	Red	Loss of power or driveability. Do not drive the vehicle. Report the fault to a Jaguar Dealer.
RESTRICTED PERFORMANCE	Amber	Loss of power or driveability. Report fault to Jaguar Dealer. The vehicle may still be driven.
	Red	Loss of power or driveability. Report fault to Jaguar Dealer. The vehicle may still be driven.
CHECK FUEL FILLER CAP	None	Fuel filler cap is open.
HOOD OPEN	Red	Check that the hood is closed securely.
TRUNK OPEN	Red	Check that the luggage compartment is closed securely.
TRANSMISSION FAULT	Amber	Transmission defaults to a limp home mode giving reduced operation. Drive with caution. Report fault to a Jaguar Dealer immediately.
HIGH TRANSMISSION TEMPERATURE	Amber	Transmission defaults to 'hot mode' to aid cooling. The vehicle may still be driven.
PARKBRAKE ON	Red	Check that the parkbrake is fully OFF.
CHECK REAR LIGHTS	Amber	Rear bulb failure.
LOW BRAKE FLUID	Red	Brake fluid is low.

4-10 On the road

Message	Priority Indicator	Meaning
LOW OIL PRESSURE	Red	Low oil pressure. This message is only displayed when the oil pressure gauge is fitted.
BATTERY NOT CHARGING	Red	Battery voltage is too high or too low or alternator indicates a fault. This message is only displayed when the battery condition indicator gauge is fitted.
WASHER FLUID LOW	Amber	Check the fluid in the windscreen washer reservoir.
SUSPENSION FAULT	Amber	Adaptive damping failure (where fitted). Report fault to a Jaguar Dealer. The vehicle may still be driven.
ELECTRICAL FAULT	Amber	Ignition supply fault. Possible reduced electrical operation. Most warning lamps will not operate. Report fault to a Jaguar Dealer immediately.
VALET MODE	None	Displayed for 3 seconds when the valet mode is activated and if interior luggage compartment release is pressed in valet mode.

Message	Priority Indicator	Meaning
<p>The following messages and associated warning lights will only appear if adaptive cruise control (ACC) is fitted and active. See Adaptive cruise control (ACC) on page 4-28.</p>		
FWD ALERT ON (or OFF)	None	Forward alert on (or off).
FWD ALERT < - - - >	None	Forward alert sensitivity adjustment.
SET SPEED XXX MPH	None	Adaptive cruise control set speed.
GAP < - - - >	None	Adaptive cruise control set distance (time gap).
DRIVER INTERVENE	Red	Driver intervention required.
CRUISE NOT AVAILABLE	Amber	Adaptive cruise control malfunction.
CRUISE CANCELLED	None	Cruise control has been deactivated.
CRUISE OVERRIDE	None	Driver is pressing the accelerator pedal.
ACC SENSOR BLOCKED	Amber	Adaptive cruise control sensor field of view is obstructed.

4-12 On the road

Audible warnings

Various sounds are produced for warning and notification purposes as follows:

Hazard or Condition	Remedy/chime or tone
External lamps remain ON when the driver's door is opened.	Intermittent slow high-pitched chime for 10 seconds. Switch the lights OFF or close the driver's door.
Hazard warning indicators ON.	A ticking will sound until the hazard indicators are switched OFF.
Left or right direction indicators ON.	If the switch has not turned itself OFF, switch the turn indicator OFF when the manoeuvre is completed. A ticking will sound until the indicators are switched OFF.
Memory 1 or 2 configuration saved.	A short tone as the memory selection is saved.
Airbag system failure. (The audible warning only sounds in the event of airbag warning light failure.)	A high-pitched tone sequence is repeated five times every thirty minutes. Report the fault to a Jaguar Dealer as soon as possible.
Driver's seat belt unfastened with ignition switch in position 'II' (Taiwan and Middle East markets only).	A continuous 6 second tone. Fasten the driver's seat belt or switch ignition to position '0'.
Parkbrake ON warning.	A single high-pitched tone will sound when the vehicle reaches approximately 3 mph (5 km/h).
Luggage compartment release switch pressed when in valet mode or valet switch pressed when the luggage compartment is closed.	Low-pitched 1 second tone.

Hazard or Condition	Remedy/chime or tone
Park not selected with the ignition OFF.	Rapid interrupted low-pitched tone for 10 seconds.
Convertible top starting to close or open.	High-pitched single chime.
ACC Driver intervene.	Action is required by the driver to apply the brakes.

4-14 On the road

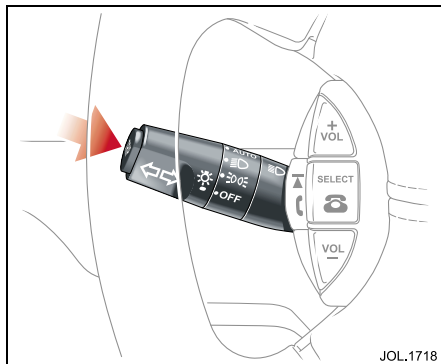

Trip computer

The computer memory stores data for a journey or series of journeys until it is reset to zero. Two independent memories are available (A and B) to allow two separate journeys to be recorded concurrently, e.g. work usage and evening/weekend usage.

All trip data displayed, apart from 'Range' and 'Instantaneous Fuel Usage' will be prefixed by the letter A or B depending on which trip memory was last selected.

The information is for guidance only, as it can be affected by traffic, road and weather conditions.

To display trip data on the message centre the ignition must be in position 'II'. Press the function button repeatedly to display the data in the following order:

Odometer

Total vehicle distance travelled.

Trip distance

Distance travelled since the last memory reset. The maximum trip reading is 9999.9 miles (16090 kilometres). The computer will automatically reset to zero if this distance is exceeded.

Range

Distance that the vehicle should travel on the remaining fuel, assuming average speed and fuel consumption stay constant.

Fuel used

The amount of fuel used since the last memory reset.

Average fuel

The display shows 'AVE FUEL'. Average fuel consumption since the last memory reset.

Instantaneous fuel usage

The display shows 'INST FUEL USAGE'. The 'at the moment' fuel consumption, calculated over a 3 second period and continuously updated.

Average speed

For the distance travelled since the last memory reset.

Note on using the trip computer:

1. 'Range' and 'Instantaneous Fuel Usage' data is independent from the trip computer and cannot be reset. The data is common to both trip memories and is not prefixed by A or B on the display.

The trip memory data cannot be reset to zero if either 'Range' or 'Instantaneous Fuel Usage' is displayed.

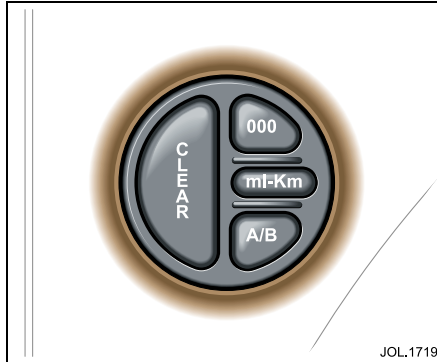

The trip computer switchpack

000 – Sets the selected trip to zero.

A/B – Toggles between trip memories A and B, while memory data is displayed.

ml-Km – Selects metric or imperial data display.

CLEAR – Used to cycle through TRIP – ODO – MESSAGES.

Note: The ‘A/B’ and ‘ml-Km’ buttons are also used for the message centre language selection feature.

Trip data display

Warning and Information messages have priority over trip data and, if active, will be displayed when the ignition is ON.

To hide warning messages and display trip data, press the CLEAR button.

Note: If messages are not hidden, trip data can still be selected by using the function button. Trip data will be displayed for 10 seconds before the message is displayed again.

Resetting the trip computer

At the start of the journey, or series of journeys, to be recorded, reset the computer memory to zero as follows:

1. Press the trip function button to select a computer function. The computer will display either trip A or trip B data.
2. Press the A/B switch to select the trip (A or B) to be reset.
3. Press the 000 switch and hold for 3 seconds.

The display will read:

A: TRIP RESETTING

or

B: TRIP RESETTING

Then it will reset and display:

A: 0.0

or

B: 0.0

Note: Only the trip displayed (A or B) will be reset.

Selecting Metric/Imperial display

Pressing the ‘ml-Km’ switch displays data in metric or imperial units alternately. The units used for computer functions are:

FUEL USED – Gallons/Litres.

AVERAGE FUEL – miles per gallon/Litres per 100 km.

INSTANTANEOUS FUEL – miles per gallon/Litres per 100 km.

Language selection

To obtain the language selection feature, press and hold the ‘ml-Km’ switch on the trip computer switchpack whilst turning the ignition key to position ‘II’.

The first language displayed is the one currently selected. The language will be displayed for 10 seconds.

To cycle through the language options, press the ‘ml-Km’ switch repeatedly.

When the language required is displayed press the ‘A/B’ switch. The new language will be selected and displayed for a 2 seconds.

Press CLEAR or start the engine to display the odometer reading. (The odometer reading is automatically displayed after 10 seconds.)

4-16 On the road

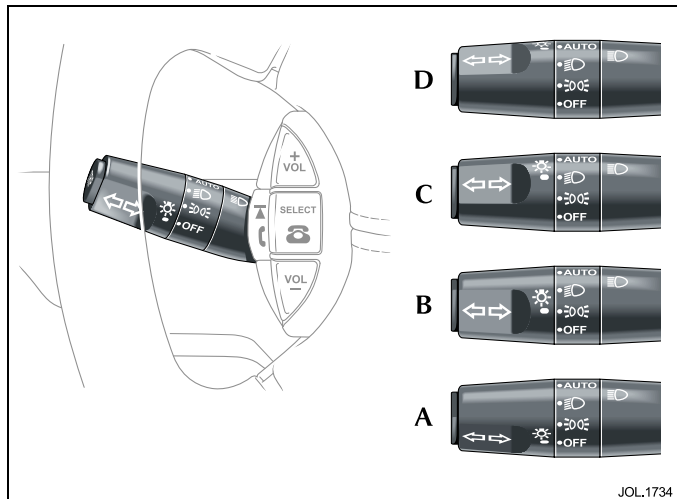

Exterior lighting

All the exterior lights, with the exception of the front and rear fog lamps, are controlled by the left-hand column switch.

Note: The button on the end of the column switch cycles through the message display functions.

Sidelights, dipped headlamps and day time running lights

The rotary collar switch on the column has four positions:

Position (A) – OFF

All exterior lights off.

Canada only: Dipped headlamps, sidelights, tail, number plate and side marker lights will switch on automatically when the ignition is turned to position 'II'.

Position (B) – sidelights ON

Switches on front sidelights, tail, number plate and any other marker lights required by local legislation. In this position the sidelight icon is illuminated.

Canada only: All lights illuminated in position (A) remain on, except the dipped headlamps.

Position (C) – headlamps ON

With the ignition in position 'II', the headlamps switch on in addition to the lights illuminated in position (B).

If the ignition is switched to position '0' with the rotary collar in position (C), the sidelights, tail and number plate lights will remain on but the headlamps will switch off. When the ignition is again switched to position 'II', the headlamps will illuminate automatically.

Position (D) – auto headlamps

This facility causes the sidelights and dipped headlamps to switch on and off automatically in accordance with the external, ambient light level. The external light is monitored by a sensor mounted behind the interior rear view mirror.

To operate: With the ignition switch in position 'II', turn the rotary collar to AUTO position (D).

When the ambient light fades to a predetermined level, the sidelights and headlamps will automatically switch on after a short delay and the sidelight icon will illuminate.

When the ambient light increases to a predetermined level, the sidelights and headlamps will automatically switch off after a short delay.

It is recommended that the rotary collar on the column switchgear is left in the AUTO position at all times as a convenience feature.

Canada only: On vehicles fitted with daytime running lights, selection of AUTO headlamps, with the ignition in position 'II', will automatically illuminate the instrumentation to full brightness by day. When ambient light fades to a predetermined level or at night, turning on the exterior lamps allows the use of the instrument panel dimmer control switch.

Note:

1. Keep the windscreen clean and do not cover the sensor. Obstructing the light in this area may lead to unwanted operation of the sidelights and headlamps when the switch is set to AUTO.
2. If the windscreen wipers are switched on in AUTO, slow or fast modes, for more than 20 seconds, then the exterior lights will be switched on, if selected to autolamps mode. The lights will switch off 2 minutes after the wipers are switched off or will go off straight away if autolamps is deselected or the ignition is switched off.

Headlamp main beam (high beam)

With the lighting switch in the Headlamps ON position (C), push the column switch away from the steering wheel. The blue warning light on the instrument cluster comes ON.

To flash the main beam headlamps, pull the column switch towards the steering wheel. The headlamps will remain ON for as long as the switch is held.

The main beam can be flashed with the ignition ON or OFF and the lighting switch in any position.

Note: Always switch to dipped headlamps when approaching traffic or when driving in urban areas.

Headlamp convenience

When approaching the vehicle, the sidelights and dipped headlamps can be switched ON by pressing the 'headlamp' button on the key-ring transmitter. The lights will come ON for 25 seconds or until the 'headlamp' button is pressed again.

4-18 On the road

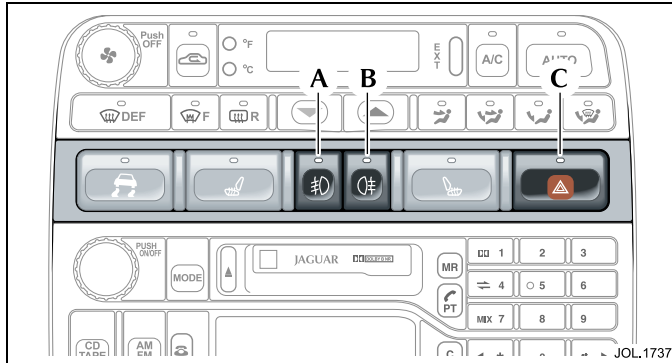

Front fog lamp (A): Only works with the ‘sidelights’ or ‘headlamps’ switched ON.

Front fog lamps should not be used in conjunction with the headlamp main beam (high beam).

Rear fog lamp (B): Only works with the headlamps switched ON or the front fog lamps switched ON.

Press to switch the fog lamps ON. Press again to switch OFF. LEDs in the switches indicate when the fog lamps are ON.

When the sidelights are switched OFF, the fog lamps will automatically be cancelled.

If the sidelights switch is left ON when the ignition switch is turned to position ‘0’, the fog lamps will switch OFF until the ignition switch is returned to position ‘II’.

Hazard warning switch (C)

The switch is in the centre console switchpack and operates with the ignition ON or OFF.

Press to switch the lamps on. The direction indicators, repeaters (where fitted), tell-tales and audible warning will operate in unison. The switch will light up. To cancel, press the switch again.

Bulb failure monitoring

The tail and brake light bulbs are monitored for failure.

Message: **Check Rear Lights**

Priority Indicator: **Amber**

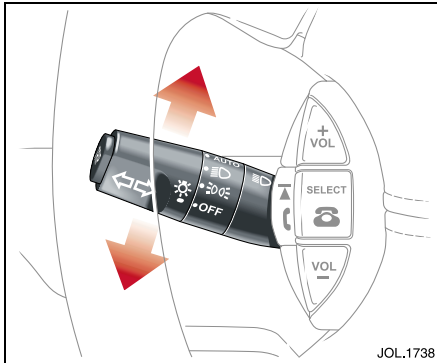

An audible ticking and a flashing green arrow on the instrument cluster indicates that the selected direction indicator is ON.

Should a direction indicator bulb fail, the corresponding side green warning light will flash at twice the normal rate. The audible ticking will sound at twice the normal rate.

Direction indicators

The direction indicators operate when the ignition is in position 'II'.

The left column stalk has two positions for indicating left or right turn.

The first position, moving the stalk up or down, causes the indicator to flash while it is held in this position. On releasing the stalk the indicators stop flashing.

The second position is a full movement of the stalk up or down to indicate for a right or left turn, which can then be released. The indicators will remain flashing and will cancel when the turn is completed.

4-20 On the road

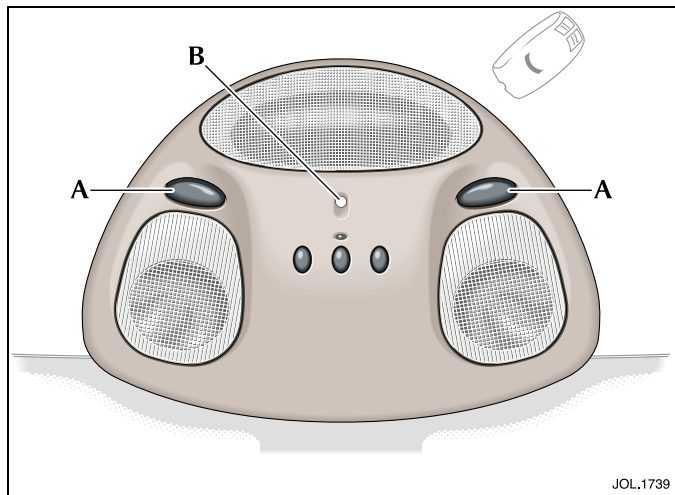

Interior lighting

Interior lights are fitted in the roof console (map lights and a low level amber light [B]) and the driver and passenger footwells. The rear of the cabin is lit by a single roof mounted light (coupe only).

The interior lights can be switched ON independently by pressing the appropriate switch (A). If the ignition is in position '0' the light will go out after 15 minutes. The amber roof light (B) is switched ON with the exterior lights and the illumination level is set by the instrument panel dimmer control.

All interior lights fade ON and fade OFF when switched. For driver convenience, the lights operate in the following manner:

The lights come ON when either door is opened and stay ON for 15 seconds after both doors are closed. If a door is left open the lights will go out after 2 minutes. If the doors are closed after 2 minutes, the lights will come ON again for 15 seconds. If the engine is running the lights go out as soon as both doors are closed.

Locking the vehicle or starting the engine switches the lights OFF immediately.

When the vehicle is unlocked by either key or key-ring transmitter, the lights will come ON at $\frac{3}{4}$ maximum brightness (for a maximum of 2 minutes if the door is not opened) and then switch to maximum brightness when a door is opened.

Note: The luggage compartment, vanity mirror and glove box are illuminated when in use. These lights and the map lights will work for up to 15 minutes after the ignition has been switched to position '0', if no other switch is operated.

Door guard lights

Door guard lights are fitted to each door to illuminate the 'step-out' area at night and to give warning of an open door to overtaking vehicles.

The light comes ON automatically when the door is opened and switches OFF when the door is closed.

If the door is left open the light remains ON for 5 minutes and then switches OFF.

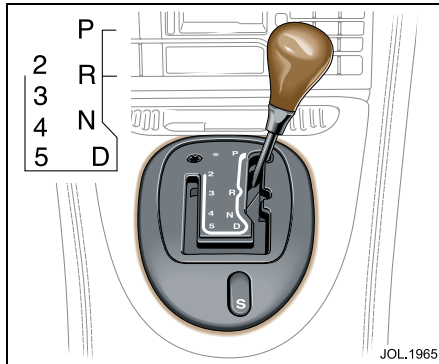

Automatic transmission

The six-speed automatic transmission is designed to accommodate different driving styles and automatically adapt shift patterns to suit varying road/driving conditions.

The switch marked 'S' on the 'J' gate surround enables the driver to select either normal 'N' or sport 'S' transmission modes.

In addition to the 'switched' transmission modes ('N' and 'S') the transmission control module will select shift patterns to suit specific conditions. These are:

Cruise control – When cruise control is operating at set speed the transmission selects a shift pattern to suit cruise control operation.

Dynamic stability control – When dynamic stability control is switched ON and the system is activated, the transmission selects a shift pattern to suit dynamic stability control conditions.

Gradients – When the vehicle is being driven on roads with uphill gradients, the transmission selects a shift pattern designed to make better use of engine power and aid engine cooling.

Under the conditions described above, the relevant transmission mode will override the 'N' or 'S' modes selected by the driver. When such conditions no longer exist, e.g. Cruise Control switched OFF, the transmission will revert to the shift pattern previously selected by the driver, i.e. 'N' or 'S'.

'J' Gate selector

The 'J' gate gear selector lever is designed to accommodate two different driving techniques as follows:

1. **Automatic selection.** The right-hand side of the selector gate is less cluttered than a conventional selector.
2. **Manual selection.** The left-hand side of the selector gate may be used for manual selection.

Note: Both sides of the 'J' gate can be used irrespective of the transmission mode, e.g. with 'S' selected the transmission can be operated in full automatic or by manual selection.

Gear selector positions



WARNING:

The parkbrake or brake pedal must be applied before selecting forward or reverse drive from a stationary position.

Note:

1. After selecting forward or reverse drive ranges from Neutral or Park, wait briefly for the transmission to engage before accelerating.

4-22 On the road

2. When in Neutral or Park the engine can only be accelerated to 4500 rev/min (all cars).

P Park – Only use when parking. Apply the parkbrake before selecting park.

R Reverse – Do not select if the vehicle is moving forward.

The reversing lights come ON automatically with 'R' selected and the ignition switch in position 'II'.

N Neutral – Disconnects the driveline from the engine. Use with the parkbrake when stopping temporarily.

D Drive – All six gears are changed automatically as required by the throttle position and road speed.

2, 3, 4, 5 – Second, third, fourth, fifth – If selected, the transmission operates automatically but will not engage gears higher than the one selected.

Drive to fifth

When driving in gear position 'D' with sixth gear engaged, the gear selector can be shifted horizontally across the gate to '5'. Provided that the vehicle's speed is not too great, the transmission will shift down to fifth.

Sixth will be inhibited until the gear selector is moved back to 'D'.

Starting and stopping

The engine cannot be started until the gear selector is in 'N' or 'P'.

When the vehicle is stationary the gear selector may be left in 'D', '2', '3', '4' or '5', unless the vehicle is to be parked.

When stopping for traffic lights, junctions etc., apply the parkbrake and select 'N'.

Note: When the ignition switch is in position '0', an audible warning will sound for 10 seconds if the gear selector is not in 'P'.

Engine braking on downhill gradients

To achieve appropriate levels of engine braking when driving on roads with long downhill gradients, position '3' or '2' may be selected depending on road and traffic conditions.

When the gear selector is moved from 'D', '5', '4' or '3' down to '2', downshift to second gear will only take place at appropriate road speeds.

Reverse inhibit

Selecting reverse is inhibited when the vehicle is moving forward above 5 mph (8 km/h).

Note: Reverse inhibit will not function in limp home mode.

Kickdown

Kickdown is operated when the accelerator pedal is pressed fully down, beyond the normal operating spring pressure, to provide maximum engine performance. Kickdown is used in circumstances where rapid acceleration is required, such as when overtaking.

Kickdown causes the transmission to change down to the lowest gear possible to achieve maximum acceleration. The gear engaged depends on the road speed at the time of kickdown.

As well as shifting down, the gear-shift points are extended to give greater performance. This mode is in effect for as long as the pedal is pressed fully down.

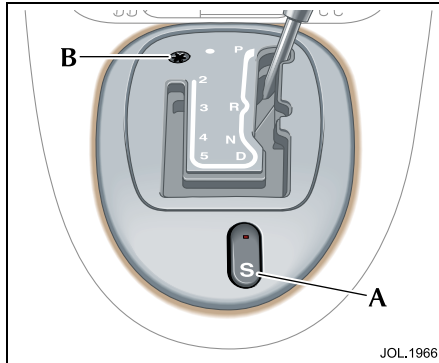

Sport mode

Switch (A) selects either normal 'N' or sport 'S' mode.

When sport mode is selected the gear-shift points are extended to make full use of the engine's power reserves.

To operate: Press the switch (A). The switch lights up to indicate that sport mode has been selected. Press the switch again to cancel sport mode.

Gear-shift interlock

A brake pedal/gear-shift interlock system is incorporated in the gear selector mechanism. Once the ignition key has been removed, the gear selector is locked in position 'P'. Also the ignition key cannot be removed from the ignition until the gear selector has been moved to position 'P'.

To move the gear selector from position 'P':

1. Turn the ignition key to position 'II' or start the engine.
2. Press the brake pedal.

To remove the ignition key move the gear selector to Park 'P'.

Gear-shift interlock manual override

In the event of the gear-shift interlock failing to operate, the gear selector can be unlocked from the 'P' position manually as follows:

1. Apply the parkbrake.
2. Remove the screw-in plug (B) using a suitable tool.
3. Insert the ignition key (or similar shaped tool) into the hole.

4. Push the key/tool down gently and hold whilst simultaneously moving the gear selector out of 'P', but not into Reverse.

Caution: Do not move the gear selector fully into Reverse until the ignition key/tool has been removed from the 'J' gate.

5. An audible warning will sound when the gear selector is moved from 'P' provided the ignition is OFF.
6. Remove the ignition key/tool and move the gear selector into Neutral for starting. Refit the plug.

4-24 On the road

Limp home mode

In the unlikely event of an electrical or mechanical failure, transmission operation will be impaired. The vehicle gear selector ranges P, R, N, D can still be used to enable the vehicle to be driven to a safe area.

The driver should be aware that the vehicle's performance will be reduced and must take this into account when driving. In this event consult a Jaguar Dealer **immediately**.

Message: **Transmission Fault**

Priority Indicator: **Amber**

For details of vehicle recovery, see **Vehicle recovery** in Section 6.

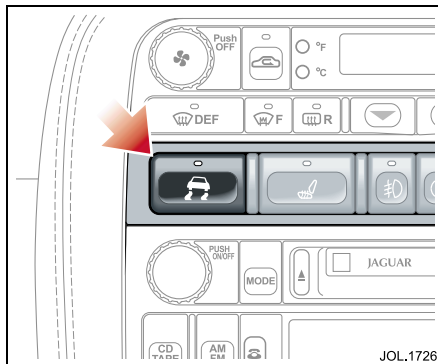

Dynamic stability control (DSC)

Unless it has been switched off, dynamic stability control is operational whenever the engine is running. When the system is operating, the warning lamp in the instrument cluster will flash.

The DSC system controls the anti-lock braking system (ABS), traction control and yaw control of the vehicle.

Yaw control determines the vehicle's direction relative to the driver's inputs (sideslip and under/oversteer). It applies braking pressure to individual wheels if excessive variation is detected.

This ensures that the vehicle follows the driver's intended directional travel.

Traction control will intervene to prevent wheel spin, by automatically reducing the power output from the engine and applying braking to individual wheels.

This improves acceleration, particularly on surfaces with uneven friction, for example, one wheel on ice the other on tarmac.

ABS helps to prevent the road wheels from locking and skidding during emergency braking.

The dynamic stability control system can be switched OFF by pressing the switch on the centre console switchpack. The warning lamp in the instrument cluster will remain on and a message will be shown to indicate that the system has been switched OFF. If the switch is pressed again the system is switched ON.

Note: If cruise control is engaged it will automatically disengage if stability control activates.

A system malfunction is indicated by the message:

DSC FAULT

Priority Indicator: **Amber**

It is safe to drive the vehicle but the system may not activate under wheel spin or slide conditions. Report the fault to a Jaguar Dealer as soon as possible.



WARNING:

1. **The fact that the vehicle is fitted with Dynamic Stability Control must never allow the driver to be tempted into taking risks which could affect his/her safety or that of other road users. In all cases it remains the driver's responsibility to drive safely according to the prevailing conditions.**
2. **It is recommended that, if using snow chains, DSC should be switched OFF.**

Anti-lock braking system (ABS)

This system helps to prevent the road wheels from locking and skidding during emergency braking, assisting the driver to maintain full steering and directional stability.

The factor controlling ultimate stopping distance and cornering ability is tyre/road adhesion.



WARNING:

1. **It remains the driver's responsibility to drive safely according to prevailing conditions.**
2. **The fact that a vehicle is fitted with ABS must never allow the driver to be tempted into taking risks which could affect his/her safety or that of other road users.**
3. **The addition of ABS cannot overcome the consequences of trying to stop in too short a distance, cornering at too high a speed, or the risk of aquaplaning.**

4. **The driver should always take road conditions into account. A slippery road surface always requires more braking distance for a given speed, even with ABS. A possible increase in stopping distance compared to locked wheels may occur during ABS operation on slushy snow, gravel, sand, or some heavily corrugated or ridged warning sections of road surfaces.**

ABS optimises tyre/road adhesion under maximum braking conditions though it cannot provide increased cornering ability. There is no need for special braking techniques, such as 'pumping' the brakes, to achieve optimum braking distances and control on poor or slippery road surfaces. Tyres must be in good condition to achieve maximum adhesion.

During normal braking the ABS will not be activated. However, if the braking force applied begins to exceed tyre/road adhesion the ABS will automatically activate, preventing the road wheels from locking.

In these circumstances a pulsating effect will be felt from the brake pedal indicating that the system is functioning.

4-26 On the road

The pulsating effect is due to small fluctuations in pressure supplied to the brakes by the system to maintain full tyre/road adhesion.

Under severe braking on some road surfaces tyre noise may be apparent even though the wheels will at no time become locked.

ABS monitoring

The ABS control module monitors the ABS electrical system from ignition switch ON to ignition switch OFF.

Any malfunction will be indicated by the anti-lock warning light coming on.

Should a fault develop in the ABS system, the brake system will still operate conventionally and with the same standard of performance as vehicles not equipped with ABS.

Caution: Consult a Jaguar Dealer immediately if the warning light comes on while driving, a system failure is indicated.

Advice on ABS braking techniques

For optimum ABS performance the instructions on braking techniques during ABS operation should be followed:

1. Do not release brake pressure when the pulsating effect is felt. Maintain a constant pressure until the manoeuvre is completed.
2. To familiarise yourself with the feel of the brake pedal during ABS braking, practise an emergency stop procedure, always making sure it is safe to do so. With the seat belts fitted to all occupants, drive the vehicle at 20 mph (32 km/h) and brake sharply.
3. ABS enables the driver to steer around obstacles during emergency braking. However, the consequences of turning sharply at high speed cannot be overcome by the ABS.
4. Do not attempt to 'pump' the brakes to avoid skidding as this can interfere with the ABS operation. The ABS will not allow the wheels to skid under normal road conditions.
5. The ABS will tend to keep the vehicle straight during braking. Because braking distances may increase under certain road conditions, it is necessary to plan and make turning manoeuvres as early as possible.

Cruise (speed) control

The cruise (speed) control system can be used by the driver to maintain a selected vehicle speed above 15 mph (24 km/h) without the driver having to use the accelerator. Switches on the steering wheel allow the driver manual control of the system. Brake and clutch operation also influences the cruise control system.

(A) – SET + to set the speed or accelerate.

(B) – ‘-’ Decelerate.

(C) – RES to resume the set speed retained in memory.

(D) – CANCEL cancels cruise control but retains the set speed in memory.

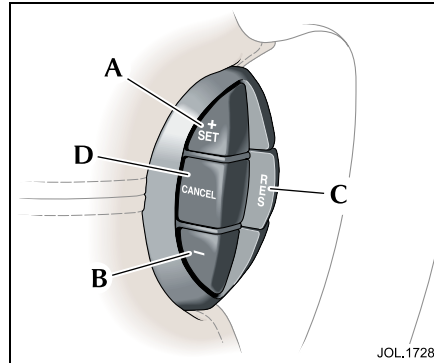

Setting vehicle speed



WARNING:
 Only use cruise control when conditions are favourable, for example, straight, dry, open roads with light traffic.

When you are travelling at the speed you require, which must be above 15 mph (24 km/h), press the SET button.

Cruise control will engage and maintain the set speed and you can remove your foot from the accelerator pedal.

Note: Cruise control will automatically disengage when the brake pedal is pressed or when the vehicle speed falls below 15 mph (24 km/h).

Changing the set speed

There are three ways to change the set speed:

1. Accelerate or decelerate to the desired speed then press the SET (+) button.
2. Increase or decrease the speed by pressing and holding either SET (+) or (-) until the desired speed is obtained, then release the switch.
3. Increase or decrease the speed in steps of 1 mph (2 km/h) by briefly pressing either the SET (+) or (-) until the desired speed is obtained.

4-28 On the road

Resuming the set speed

If the vehicle is accelerated above the set speed, then the set speed will be resumed when the accelerator pedal is released.

If CANCEL is pressed, or the brake or clutch pedal is pressed, the cruise control will disengage but the set speed memory will be retained. Press RESUME and the vehicle will return to the set speed.

Note: Cruise control will not resume at speeds below 15 mph (24 km/h).

RESUME will not operate if the ignition has been turned off.

Caution:

1. **RESUME should only be used if the driver is aware of the set speed and intends to return to it.**
2. **It is not recommended to resume set speed when a low gear is selected as excessive engine speeds will occur.**

Cruise control automatic switch off

Cruise control will switch off and clear the memory when:

- The ignition is switched to position '0'.

- A fault occurs. The cruise control system will switch OFF and cannot be used until the fault is cleared.
- The parkbrake is applied.
- Maximum vehicle speed is reached.

Cruise control will switch off but the set speed will remain in the memory when:

- The CANCEL button is pressed.
- The brake pedal is pressed.
- Speed falls below 15 mph (24 km/h).
- Neutral, Park or Reverse gear positions are selected.
- Traction control or DSC is operating.
- The difference between the actual and set speed is too great.
- When the set speed is above 90 mph (144 km/h); cruise control will disengage automatically after approximately 20 minutes.
- The accelerator pedal is used to accelerate beyond the set speed for too long a period.

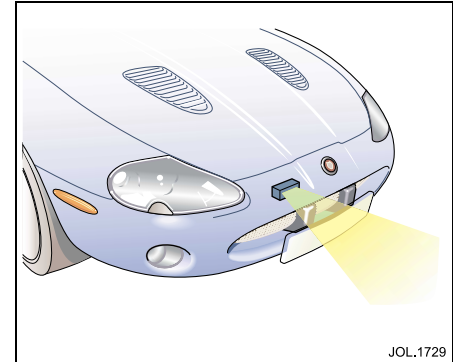

Adaptive cruise control (ACC) (Where fitted)

The adaptive cruise control system is designed to aid the driver to maintain a gap from the vehicle ahead or a set road speed if there is no slower vehicle ahead. The system is intended to provide enhanced operation of the vehicle when following other vehicles which are in the same lane and travelling in the same direction.

The adaptive cruise control system is based on the use of a radar sensor which projects a beam directly forward of the vehicle so as to detect objects ahead.

The radar sensor is mounted behind a cover on the left-hand side of the lower cooling aperture, to provide a clear 'view' forward for the radar beam.



WARNING:

Adaptive cruise control is not a collision warning or avoidance system. Additionally, adaptive cruise control will not detect:

- 1. Stationary or slow moving vehicles below 6 mph (10 km/h).**
 - 2. Pedestrians or objects in the roadway.**
 - 3. Oncoming vehicles in the same lane.**
- Only use adaptive cruise control when conditions are favourable, that is, straight, dry, open roads with light traffic.
 - Do not use in poor visibility, specifically fog, heavy rain, drizzle or snow.
 - Do not use on icy or slippery roads.
 - It is the drivers responsibility to stay alert, drive safely and be in control of the vehicle at all times.

- Keep the front of the vehicle free from dirt, metal badges or objects, including vehicle front protectors, which may prevent the sensor from operating.
- Do not use ACC when entering or leaving a motorway.

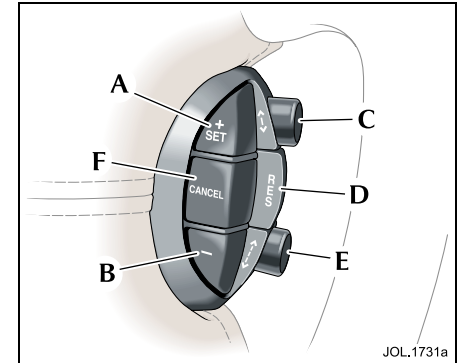

The system is operated by six switches mounted on the steering wheel. The driver can also intervene at any time by use of the brake or accelerator pedals. The steering wheel switches operate as follows:

- (A) – ‘SET +’: Set speed or accelerate.
- (B) – ‘-’: Decelerate.
- (C) – ‘<->’: Gap decrease.
- (D) – ‘RES’: Resume set speed.
- (E) – ‘<--->’: Gap increase.
- (F) – ‘CANCEL’: Cancels without erasing memorised speed.

4-30 On the road

Setting a speed

Accelerate as normal until the required speed is reached.

Press the 'SET +' button (A) briefly and the vehicle speed will then be stored in the memory and the system engaged. The set speed will be displayed on the message centre.



Entering the follow mode



WARNING:

When in follow mode the vehicle will not decelerate automatically to a stop, nor will the vehicle always decelerate quickly enough to avoid a collision without driver intervention.

Once a set speed has been selected, the driver can release the accelerator and the set road speed will be maintained.

When a vehicle ahead enters the same lane or a slower vehicle is ahead in the same lane, the vehicle speed will be adjusted automatically until the gap to the vehicle ahead corresponds to the preset gap. The vehicle is now in 'follow mode'.



The warning light in the instrument cluster will be illuminated.

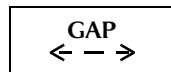

And the message centre will display the gap set.

The vehicle will then maintain the constant time gap to the vehicle ahead until:

- The vehicle ahead accelerates to a speed above the set speed.
- The vehicle ahead moves out of lane or out of view.
- The vehicle ahead slows so that 'low speed automatic switch off' occurs.
- A new gap distance is set.

If necessary, the vehicle brakes will be automatically applied to slow the vehicle to maintain the gap to the vehicle in front.

The maximum braking which is applied by the ACC system is limited and can be overridden by the driver applying the brakes, if required.

Note: Driver braking will cancel adaptive cruise control.

If the ACC system predicts that its maximum braking level will not be sufficient, then an audible warning will sound while the ACC continues to brake. This is accompanied by a red warning light and 'DRIVER INTERVENE' will be displayed on the message centre. The driver should take IMMEDIATE action.

When in follow mode the vehicle will automatically return to the set speed when the road ahead is clear, for instance when:

- The vehicle in front accelerates or changes lane.
- The driver changes lane to either side or enters an exit lane.

The driver should intervene if appropriate.

Low speed automatic switch off

If the speed of the vehicle decreases below 18 mph (30 km/h), the ACC system will be automatically switched OFF and the instrument warning lamp will go out.

If the brakes were being applied by the ACC system, they will be slowly released.

This will be accompanied by an audible warning, a red warning light and 'DRIVER INTERVENE' will be displayed on the message centre. The driver must take control.

Overriding the set speed/follow mode



WARNING:

Whenever the driver is overriding the ACC by depressing the accelerator pedal, the ACC will not automatically apply the brakes to maintain separation from any vehicle ahead.

The set speed and gap can be overridden by pressing the accelerator pedal when cruising at constant speed or in follow mode.

If the vehicle is in follow mode, the instrument warning lamp will go out when the ACC is overridden by the driver using the accelerator.

'CRUISE OVERRIDE' will be displayed on the message centre. When the accelerator is released the ACC function will operate again and vehicle speed will decrease to the set speed, or a lower speed if follow mode is active.

Changing the set speed

There are three ways to change the set speed:

1. Accelerate or brake to the required speed and press the 'SET +' button (A).
2. Increase or decrease the speed by pressing and holding either the 'SET +' or '-' button until the required set speed is shown on the message centre. The vehicle speed will gradually change to the selected speed.
3. Increase or decrease the speed in steps of 1 mph (2 km/h) by briefly pressing the 'SET +' or '-' button.

ACC operates between approximately 20 mph and 110 mph (34 km/h and 180 km/h) dependent on the country specification.

Set speeds outside this range will not be captured.

The ACC may apply the brakes to slow down the vehicle to the new set speed. The new set speed will be displayed on the message centre for four seconds after it has been changed.

4-32 On the road

Changing the gap

The gap from the vehicle ahead can be decreased or increased by pressing the rocker switches (C and E) on the steering wheel. Four gaps are available and the selected gap setting will be displayed on the message centre when either button is pressed. After the ignition is switched ON the default gap will be automatically selected ready for ACC operation.

Note: It is the driver's responsibility to select a gap appropriate to the driving conditions.

ACC automatic switch off

Adaptive cruise control will disengage, but not clear the memory when:

- The CANCEL button (F) is pressed.
- The brake pedal is pressed.
- The vehicle speed falls below 18 mph (30 km/h).
- Neutral, Park or Reverse gear positions are selected.

- The parkbrake is applied.
- Traction control is activated.

Adaptive cruise control will disengage, and clear the memory when:

- The ignition switch is set to position '0'.
- Maximum vehicle speed is reached.
- A fault occurs in the ACC system.

Resuming the set speed/follow mode

By pressing the resume button (D) after ACC has been cancelled, for example, after braking, the ACC will become active again provided that the set speed memory has not been erased. The set speed will be displayed for four seconds and the original set speed will be resumed, unless a vehicle ahead causes the follow mode to become active.

Caution: 'RESUME' should only be used if the driver is aware of the set speed and intends to return to it.

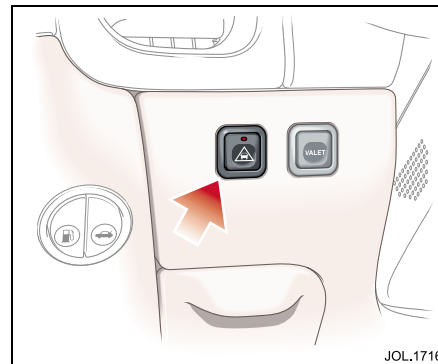

Forward alert (where fitted)

Limited detection and warning of objects ahead is provided during ACC operation by the ACC 'DRIVER INTERVENE' warning.

The forward alert feature additionally provides these warnings while ACC is not engaged; if an object is detected close ahead, then the warning message and tone will be issued. The brakes will not be applied.

This additional feature may be switched on or off using the forward alert switch in the lower outboard knee bolster switchpack.

When the indicator lamp in the switch is on, forward alert is active.

The sensitivity of the warning may be changed:

- Pressing the gap decrease button (C) when ACC is disengaged displays and then decreases the sensitivity of the alert.
- Pressing the gap increase button displays and then increases the sensitivity of the alert.

Both of these are accompanied by the FWD ALERT ← — → message on the message centre.

ACC failure

If a fault occurs during operation of the system in cruise or follow modes, the ACC system will switch OFF and cannot be used until the fault is cleared. A red warning light and the message 'DRIVER INTERVENE' appear briefly, and are then replaced by an amber warning light and the message 'CRUISE NOT AVAILABLE'.

If failure of the ACC or any related system occurs at any other time an amber warning light will be displayed accompanied by the message 'CRUISE NOT AVAILABLE'. It will not be possible to activate the ACC system in any mode.

Accumulations of dirt, snow or ice on the sensor or cover may inhibit

ACC operation. Fitting of a vehicle front protector or metallised badges may also affect ACC operation.

If this occurs in ACC cruise/follow mode, the red warning light is displayed, the audible alarm sounds and the message 'DRIVER INTERVENE' appears briefly. These warnings are then replaced by the amber warning light and the message 'ACC SENSOR BLOCKED' is displayed. The system is no longer active.

Clearing the obstruction allows the system to return to normal operation.

If the obstruction is present when ACC is inactive, e.g. on initial starting or with the ACC system switched off, the amber warning light will be displayed with the message 'ACC SENSOR BLOCKED'.

Tyres other than those recommended may have different sizes. This can affect the correct operation of the ACC.

Notes on using adaptive cruise control:

1. Adaptive cruise control operates when the gear selector lever is in position '2', '3' '4' '5' or 'D'.
2. When engaged, the accelerator pedal rests in the raised position. Fully release the pedal to allow normal ACC operation.
3. When braking is applied by the ACC the brake pedal will move down and up as braking is applied or removed. The vehicle brake lights will be switched on while braking is applied.



WARNING:
The driver must not rest a foot under the brake pedal, as it may become trapped.

4-34 On the road

Driving with ACC active

The system acts by regulating the speed of the vehicle using engine control and the brakes. Gear changes may occur in response to deceleration or acceleration whilst in ACC.

ACC is not a collision avoidance system, however, during some situations the system may provide the driver with an indication that intervention is required.

An audible alarm will sound, accompanied by a red warning light and the message 'DRIVER INTERVENE' if the ACC detects:

- That using maximum ACC braking only is not sufficient.
- That the vehicle speed has decreased below the minimum for ACC operation.
- A failure has occurred whilst the system is active.

Detection issues can occur:

- When driving on a different line to the vehicle in front (A).
- With vehicles which edge into your lane which can only be detected once they have moved fully into your lane (B).

There may be issues with the detection of vehicles in front when going into and coming out of a bend (C).

In these cases ACC may brake late or unexpectedly. The driver should stay alert and intervene if necessary.

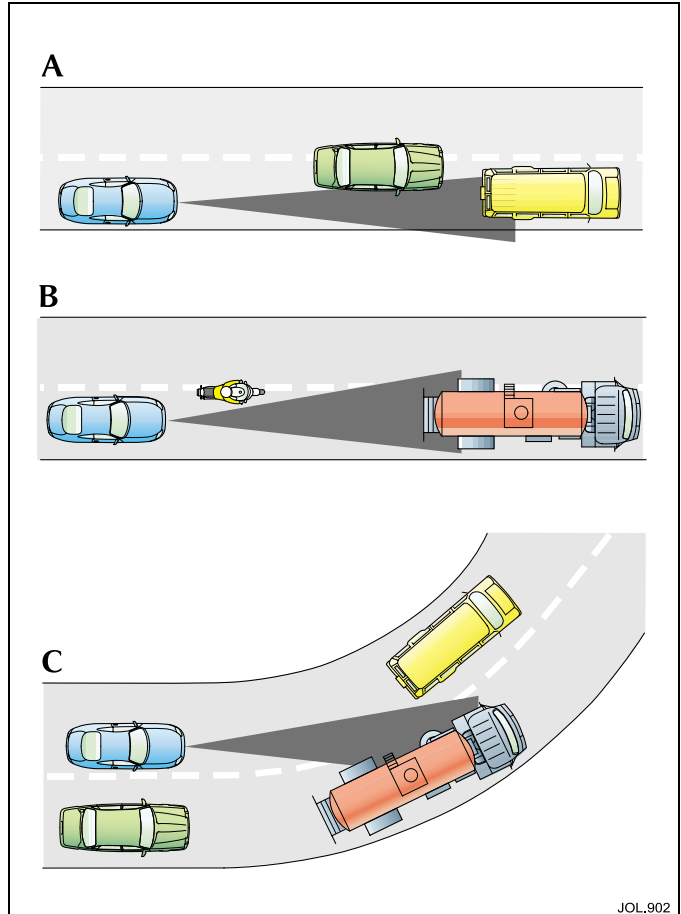

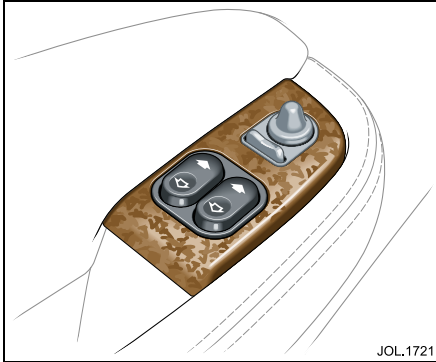

Window operation

Two switches on the driver's door switchpack control the driver and passenger door windows. The passenger is provided with a switch to control the passenger door window only.

These switches only operate:

1. When the ignition switch is in position 'I' or 'II', or
2. After the ignition has been switched OFF, until a door has been opened.



WARNING:

1. When raising windows ensure all occupants are clear.
2. When leaving the vehicle take the ignition keys to prevent misuse of the window switches by remaining occupants, especially children.
3. Obstruction detection is not available.

Operation

To open: Press and hold the lower part of the switch. Release the switch to stop movement.

To close: Press and hold the upper part of the switch. Release the switch to stop movement.

Note: If the switches are held for longer than 8 seconds, e.g. when attempting to overcome frozen or jammed windows, the window drive will be switched off for a few seconds to protect the window drive motors.

One-touch open operation

Briefly press and release the lower part of the driver's window switch – the window will fully open. Window travel can be stopped by pressing the switch again.

Automatic window drop for door opening



WARNING:

The door windows lower partially when the door is opened and raise when it is closed. Do not attempt to close the door by holding on to or pushing against the top of the glass.

The frameless door windows create a seal against the convertible top or the roof seals. If fully raised, the door windows will drop partially when the door release lever is operated; this is to allow easy door opening. When the door is closed the windows rise to the fully closed position.

The doors must not be opened if power for 'automatic window drop' is not available, e.g. with battery disconnected. However, in an emergency the doors can be opened with the windows fully up.

4-36 On the road

Re-programming door windows after power disconnection

After battery disconnection or fuse removal, the system must 're-learn' the limits of window travel. This is to ensure correct operation of the automatic window drop facilities.

Re-programming is done with the doors closed and the ignition switch in position 'I' or 'II', as follows:

1. Press and hold the lower part of the switch. When the window is fully lowered, continue to hold the switch for 5 seconds.
2. Press and hold the upper part of the switch. When the window is fully raised continue to hold the switch for 5 seconds.

Carry out this procedure for driver and passenger door windows.

Rear quarter window operation (Convertibles only)

The rear quarter windows operate automatically in conjunction with convertible top opening or closing.

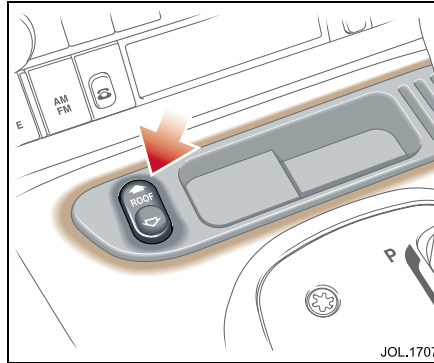

The rear quarter windows may also be operated independently of the convertible top when the convertible top is closed, by means of the ROOF switch on the centre console, as described below.

To lower: Briefly press the rear of the switch. The rear quarter windows will be driven down fully.

To raise: Press the front of the switch. The rear quarter windows will rise for as long as the switch is held.

Caution: Do not close the door with the windows fully up as damage to the seals and the glass will occur.

Notes on rear quarter window operation:

1. When the convertible top is opened the rear quarter windows are automatically lowered and cannot be operated until the top is closed. When the top is closed the rear quarter windows are automatically raised.
2. The rear quarter windows operate together and cannot be operated individually.

Holding the ROOF switch after the warning sounds will cause unwanted convertible top operation.

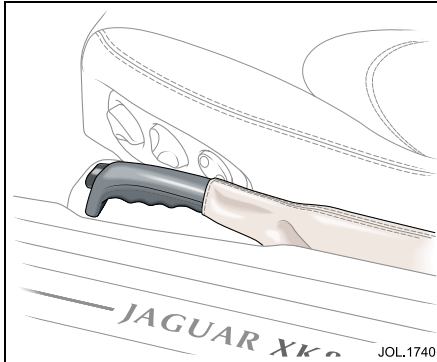

Parkbrake

The parkbrake lever is mounted on the outboard side of the driver's seat and mechanically operates the rear parking brakes.

The parking brakes are independent of the main brake system.

To apply: Lift the lever firmly.

The parkbrake should be fully ON after three or four clicks. The lever may then be returned to the lower (OFF) position with the brake still engaged. This allows the driver easy access to and from the vehicle. The **Parkbrake on** warnings will be activated (see below).

To release: Lift the lever fully, press the locking button at the end of the lever, and lower to the OFF position. If the parkbrake lever is not fully OFF, the **Parkbrake on** warnings will stay on (see below).

Parkbrake on warnings

The parkbrake warning/brake fluid low warning light will illuminate and a text message will be displayed.

Message: **Parkbrake On**

Priority Indicator: **Red**

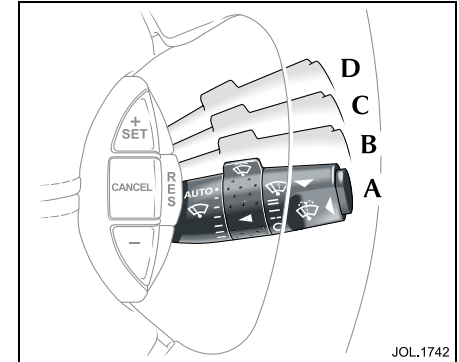

Windscreen wipers and washers

The windscreen wipers and screen wash functions controlled by the right-hand column switch, only operate with the ignition in position 'II'.

The functions are as follows:

- Position '0' (A): The windscreen wiper blades are OFF and parked.
- First position (B): Intermittent wipe.
- Second position (C): Normal wiper operation.
- Third position (D): High speed wiper operation.

4-38 On the road

Intermittent wipe

When intermittent wipe is selected, first position (B), the rotary collar can be adjusted to vary the delay between wipes. Six collar positions (five with rain sensitive wipers fitted) vary the delay from 2 seconds to 20 seconds. Turn the collar anti-clockwise to increase the delay time.

If flick wipe or wash/wipe is selected between intermittent wipes, the intermittent mode will be interrupted temporarily.

Rain sensitive wiper operation

With the rotary collar set to AUTO and intermittent wipe, position (B), selected, the wipers will automatically operate when rain or moisture is detected on the windscreen. The wipers will stop automatically when the rain has ceased and moisture is no longer detected. Ensure that the rain/moisture sensor, which is located behind the dark vertical band at the top centre of the windscreen, is not obscured.

Note: When starting a journey with a wet windscreen, the rain sensing wipers will not operate immediately the ignition is switched on, therefore, a flick wipe should be used to clear the screen of any moisture.

Caution: Ensure that AUTO is not selected when entering a car wash or damage to the wiper blades/arms can occur.

Flick wipe

Pull the column switch towards the steering wheel for a single slow speed wipe. Holding the column switch in this position will operate the wiper continually at slow speed until released.

Note: If the windscreen wipers are switched on in AUTO, slow or fast modes, for more than 20 seconds, then the exterior lights will be switched on, if selected to autolamps mode. The lights will switch off 2 minutes after the wipers are switched off or will go off straight away if autolamps is deselected or the ignition is switched off.

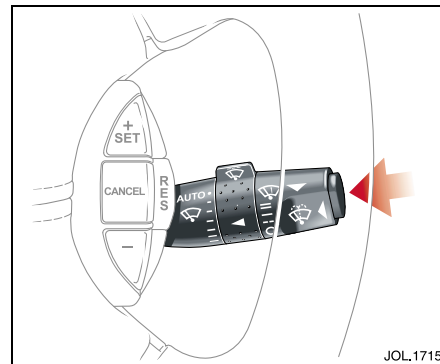

Windscreen wash operation

Push the button on the end of the column switch to obtain the wash/wipe programme. A short press will operate the washers briefly and the wipers will complete three wipes. If the button is held, the washers and wipers will operate continuously for up to 20 seconds. When released, the wipers will complete three wipes after the washers have stopped. The drip wipe function will perform a single wipe 4 seconds after the wash/wipe sequence has finished.

When the washer fluid is low, a message is displayed, and the programmed wash/wipe function is disabled. Manual operation is still available.

Message: **Washer Fluid Low**
Priority Indicator: **Amber**

Headlamp powerwash

Note: The telescopic headlamp powerwash units are contained within the headlamp cluster. When operated, the units extend under water pressure, spray the headlamps and then retract automatically into the headlamp.

The headlamp powerwash feature will operate if the ignition is in position 'II' and the lighting switch is in the dipped or main beam position (C). It will not operate if the washer fluid level is low (indicated by the message centre).

When the wash/wipe button is pressed, the headlamp powerwash directs two short bursts, approximately 6 seconds apart, at the headlamp cluster. If the wash/wipe button is held, the powerwash cycle will continue for up to 20 seconds.

The headlamp powerwash will operate the first time the wash/wipe button is pressed and thereafter every sixth succeeding wash/wipe operation. If the sidelights or ignition are switched OFF and ON again, headlamp powerwash will operate on the next press of the wash/wipe button.

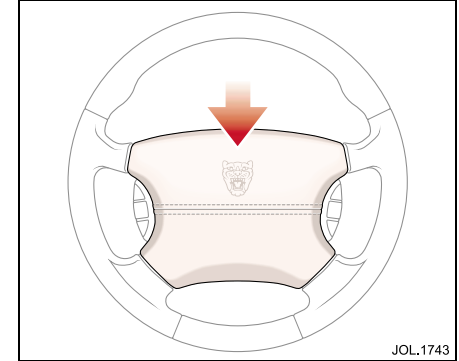

JOL.1743

Horns

Twin warning horns are operated by pressing the centre pad on the steering wheel.

The horns will not operate when the ignition switch is in position '0' and the driver's door is open.

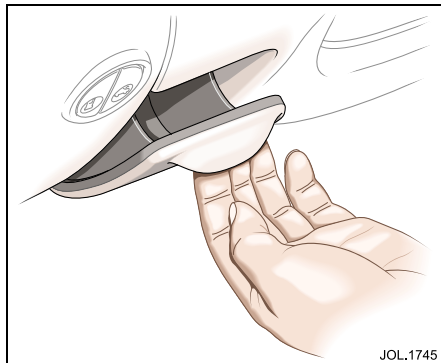

Interior features

Sunglasses storage compartment

Storage for the driver's sunglasses is provided in the driver's knee bolster.

To open: Pull down using the finger recess.

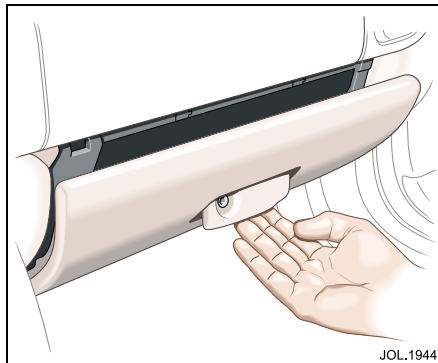

Glove compartment

A glove compartment is situated below the passenger's airbag. This compartment may be locked using the black-headed key only.

To open: Lift the handle and allow the lid to drop down. The compartment will be illuminated when open.

Note: The compartment will be illuminated for up to 15 minutes after the ignition has been switched to position '0'.

Storage is provided for: The Driver's Handbook Literature Pack, pen holder and a rechargeable torch (available as an accessory).

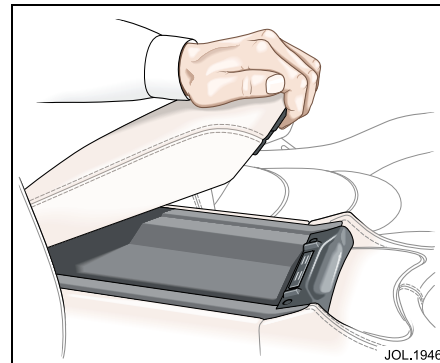

Centre console armrest

The armrest is hinged at the rear to provide access to a storage compartment, and incorporates a cupholder which is described below.

On vehicles fitted with the optional telephone, the storage compartment is fully occupied by the handset and vehicle interface.

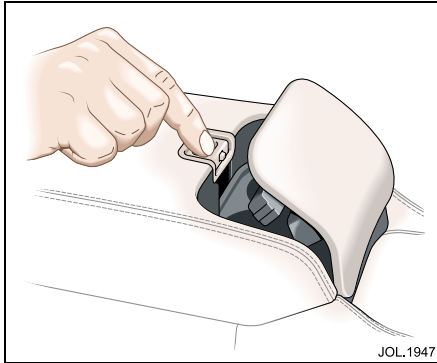

Cupholder

A cupholder for two cups is provided in the centre console armrest.



WARNING:

1. Do not place hot drinks in the cupholders whilst the vehicle is moving, there is a risk of scalding.
2. Use soft cups only.

To operate: Push the button on the armrest rearwards. After use, lower the cupholder flap and press down to engage the latch.

Do not open the storage compartment while the cupholder is being used.

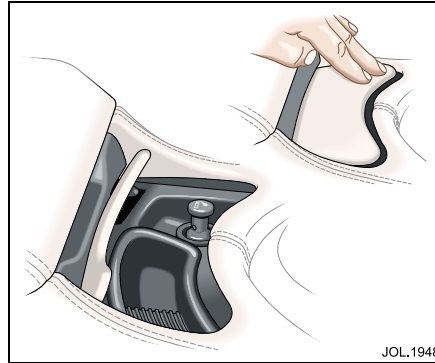

Ashtray and cigar lighter

The ashtray and cigar lighter are situated in front of the cupholder.

To open: Press the front edge of the lid which will open to reveal the cigar lighter and removable tray.

To operate the cigar lighter: With the ignition in position 'I' press down and wait until the element has heated, it will then 'pop-up'.

Note: Never hold the lighter knob down. Do not attempt to remove particles from the element, as it is self cleaning.

To empty the tray: Lift out vertically and remove.

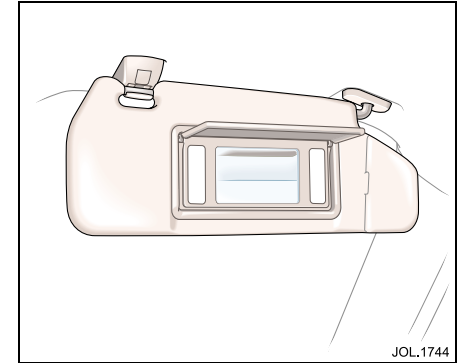

Sun visors and vanity mirrors

Adjustable sun visors can be swung downwards or unclipped and swung sideways to eliminate sun glare.

The rear of each sun visor is fitted with an illuminated vanity mirror, behind a hinged flap. The light comes ON when the flap is lifted.

Note: Vanity mirror illumination will only work when the sun visors are held in place by the stowage clips.

When positioned to the side, the sun visors can be moved forwards or rearwards on a telescopic arm, if required.

4-42 On the road

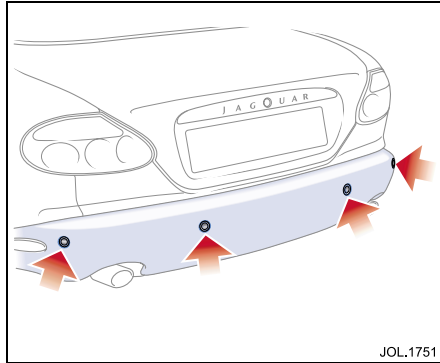

Reverse park control

Caution: It remains the driver's responsibility to detect obstacles and estimate the car's distance from them. Some overhanging objects, barriers, thin obstructions or painted surfaces which could possibly cause damage to the vehicle may not be detected by the system. Always be vigilant when reversing.

This parking aid, when reverse gear is selected and ignition on, automatically provides an audible proximity warning when reversing the vehicle. If an object is detected, a beep tone will be heard, which increases in rate as the vehicle approaches the object.

At approximately 8 inches (200 mm) the beep will become continuous for three seconds and is then automatically turned off.

Reverse park control is automatically switched off if a trailer is attached to the vehicle.

If the system has a fault when engaging reverse gear then a single, three second tone only will be heard.

Note:

1. For reliable operation, the four sensors in the rear bumper should be kept free from ice and grime.
2. When using a high pressure spray the sensors should only be sprayed briefly and not from a distance of less than 8 inches (200 mm).

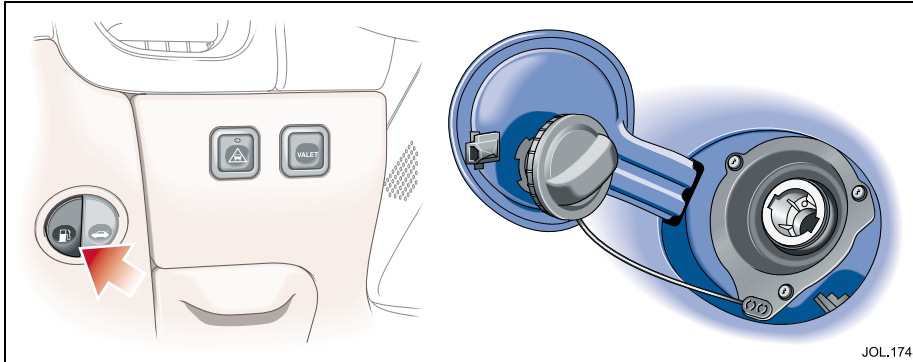

Fuel tank filling

Caution: Your vehicle is fitted with catalytic converters and must only be filled with 'Unleaded Fuel'.

The fuel filler flap release switch is located in the knee bolster switchpack below the fascia. The filler flap is on the left-hand side of the vehicle.

The switch will not operate with the engine running.

Turn the filler cap anti-clockwise and remove the cap from the filler neck.

The cap is held by a retaining strap and can be stowed against the magnetic plate on the inside edge of the filler flap to allow easy access to fill the tank.

A warning label on the inside of the fuel filler flap advises type/grade of fuel.

When filling, the dispenser nozzle must be inserted into the filler neck sufficiently to open the trap door for fuel to flow into the fuel tank. Fill the tank until the filler nozzle automatically shuts off. Filling beyond this point could result in fuel spillage.

Fuel and refuelling

Before refuelling, switch off the ignition and remove the key.

Note: Do not leave the ignition key in the vehicle; vehicles have been stolen from garage service/filling stations whilst the driver is absent from the vehicle. It is recommended that the vehicle is locked, if left unattended.

Caution: No additives of any kind (fuel or oil) must be put into the fuel tank. Additives could reduce engine life or affect exhaust emissions.



WARNING:

1. Fuel vapour is highly flammable and in confined spaces is explosive and toxic. In the event of inadvertent spillage, and before refuelling, always switch OFF the engine. Do not use exposed flame or light. Do not smoke. Do not inhale fumes.
2. Do not fill the tank so that fuel is visible in the fuel filler intake tube. This could cause spillage and danger from exposed fuel.

4-44 On the road

After refuelling, refit the filler cap in the filler neck, twist the filler cap clockwise a $\frac{1}{3}$ turn to stop position and close the flap, which automatically locks shut.

The continuous use of high quality fuel makes the need for additional additives unnecessary. This will help to protect the engine components against corrosion, carbon deposit formation and prevent the fuel injection system from clogging.

If in doubt your local Jaguar will advise on which fuel must be used in your vehicle.

Emission control components

Owing to the legislative requirements or options available in some countries, a Jaguar Dealer should be consulted where any doubt exists as to the precise emission control system specification of this vehicle.

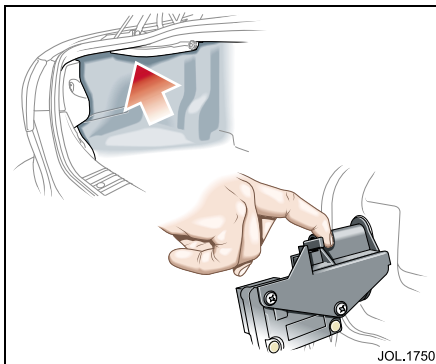

Fuel filler flap emergency release

In the event of a power failure the flap can be released as follows:

1. Remove the luggage compartment lining at the rear on the left-hand side below the filler.
2. Reach up and locate the fuel filler flap mechanism. The lock plunger has an 'L' shaped bracket at one end. Pull back the plunger to release the filler lock.

After refuelling, refit the filler cap in the filler neck, twist the filler cap clockwise a $\frac{1}{3}$ turn to stop position and close the flap, which automatically locks shut.

Fuel capacity

Avoid the risk of running out of fuel and never intentionally drive the car when the fuel gauge indicates that the tank is empty. When refuelling your vehicle after the fuel gauge reads empty, you may not be able to add the fuel quantity, shown below, to the tank as there will be a small reserve quantity remaining in the tank.

Total tank capacity	19.8 US Galls 75 litres
Fill capacity	18.5 US Galls 70 litres
Reserve capacity	1.3 US Galls 5.0 litres

Fuel economy

The following tips not only lead to greater fuel economy but also reduce air pollution causing less environmental damage:

- Try to avoid using the car for short journeys – this will lead to greater fuel economy and reduce wear on the engine.
- Plan ahead – choose uncongested routes, combine car trips and share cars where possible.
- Drive off as soon as possible after starting a cold engine – do not leave the engine idling until it has warmed up.
- Drive smoothly and efficiently – harsh acceleration and heavy braking have a significant effect on fuel consumption – driving more smoothly saves fuel.
- Slow down – driving at high speeds significantly increases fuel consumption.
- Switch off – sitting stationary is zero miles per gallon, switch off the engine when it is safe to do so.
- Unnecessary weight – do not carry unnecessary weight and remove roof racks when not in use.

- Regular servicing keeps the engine at best efficiency.
- Ensure that tyres are inflated to the correct pressure for the journey.
- Use air conditioning and all vehicle electrical devices sparingly – all increase fuel consumption.

Check your fuel consumption – it will help you get the most from your car and any significant change in consumption may indicate a vehicle fault.

Fuel requirements

The filler neck of the fuel tank is a small diameter (except Japan) to suit the unleaded fuel pump nozzle and will prevent the larger diameter leaded fuel nozzle from entering the filler neck.

Unleaded fuel

All vehicles are fitted with a catalytic system and can only use unleaded fuel.

Unleaded fuel must be used for the emission control system to operate properly.

Its use will also reduce spark plug fouling, exhaust system corrosion and engine oil deterioration.

Use only Premium unleaded gasoline with a minimum anti-knock index (AKI) of 91.

Using unleaded fuel with a lower AKI than recommended can cause persistent, heavy ‘spark knock’ (a metallic rapping noise). If severe, this can lead to engine damage.

If a heavy ‘spark knock’ is detected even when using fuel of the recommended octane rating, or if you hear steady ‘spark knock’ while holding a steady speed on level roads consult a Jaguar Dealer.

Failure to do so is misuse of the vehicle, for which Jaguar Cars Limited, is not responsible. However, occasional light ‘spark knock’ for a short time while accelerating or driving up hill, may occur.

4-46 On the road

Fuels containing alcohol

Caution: Take care not to spill fuel during refuelling. Fuel containing alcohol can cause paint damage, which may not be covered under the warranty.

Some fuel suppliers sell fuel containing alcohol without advertising its presence. Where uncertainty exists check with the service station operator.

Note: Some difficulty in starting may be encountered when using alcohol blended fuel.

Ethanol

Fuels containing up to 10 per cent ethanol (grain alcohol) may be used. Ensure the fuel has octane ratings no lower than those recommended for unleaded fuel. Most drivers will not notice any operating difference with fuel containing ethanol. If a difference is detected, the use of conventional unleaded fuel should be resumed.

Methanol

Some fuels contain methanol (methyl or wood alcohol). If you use fuels containing methanol the fuels must also contain co-solvents and corrosion inhibitors for methanol.

Also, do not use fuels that contain more than three per cent methanol even if they contain co-solvents and corrosion inhibitors. Fuel system damage or vehicle performance problems resulting from the use of such fuels is not the responsibility of Jaguar Cars Limited, and may not be covered under the warranty.

Methyl Tertiary Butyl Ether (MTBE)

Unleaded fuel containing an oxygenate known as MTBE can be used provided the ratio of MTBE to conventional fuel does not exceed 15 per cent.

MTBE is an ether based compound, derived from petroleum, which has been specified by several refiners as the substance to enhance the octane rating of fuel.

Reformulated gasoline

Several petroleum companies have announced the availability of reformulated fuels. These fuels are specially designed to further reduce vehicle emissions.

Jaguar fully supports all efforts to protect and maintain ambient air quality and encourage the use of reformulated gasoline, where available.

Catalytic converters

A few precautions on the use of vehicles fitted with catalytic converters are necessary. These are:

1. In order to maintain the efficiency of the emission control system it is essential that unleaded fuel is used. Use of leaded fuel will seriously damage the catalytic converters.
2. Heavy impact on the converter casings must be avoided.
3. The engine settings must not be altered; they have been established to ensure that the vehicle will comply with stringent exhaust emission regulations. Incorrect engine settings could cause unusually high catalytic converter temperatures and thus result in damage to the converter and vehicle.
If adjustment to the settings is considered necessary, this should be performed by a Jaguar Dealer.
4. A correctly tuned engine optimises exhaust emissions, performance and fuel economy and it is recommended that the vehicle is regularly maintained.
5. Do not continue to operate the vehicle if any engine malfunction is evident; malfunctions should be rectified immediately. For instance, misfire, loss of engine performance, excessive oil consumption or engine run-on may lead to unusually high catalytic converter temperatures and may result in damage to the converters and vehicle.
6. The use of catalytic converters increases exhaust system temperatures, therefore, do not operate or park the vehicle in areas where combustible materials such as dry grass or leaves may come into contact with the exhaust system.
7. Do not run the engine with either a spark plug lead disconnected or a spark plug removed as this could result in catalytic converter damage.
8. The vehicle is designed for normal road use. Below are examples of abuse which could damage the catalytic converters and vehicle. These may lead to a dangerous condition due to excessively high catalytic converter temperatures:
 - Competition or off-road use.
 - Excessive engine speed.
 - Overloading the vehicle.
 - Switching off the engine whilst in gear.

General driving information



WARNING:

Ensure the parkbrake is on and the automatic gear selector is in position 'P' or 'N' before attempting to start the engine.

Before driving off, check the gauges and warning lights and messages. Take special note of any warning light that is on.

Seat belts are provided for your safety and it is unwise, and in certain countries illegal, to commence any journey, however short, without wearing them.

Warming up

Do not operate the engine at high speed when first started but allow time for the engine to warm up and the oil to circulate.

Engine braking on downhill gradients

When driving on mountain roads with long downhill gradients it is advisable to select a low gear.

Running-in

Apart from a few precautionary recommendations, there are no strict 'running-in' procedures for this vehicle.

By observing the following advisory notes you will ensure maximum engine, transmission and brake life for your vehicle:

1. Allow the engine to warm up thoroughly before operating at engine speeds over 3500 rev/min.
2. Vary the speed frequently.
3. From 940 miles (1500 kilometres) onwards, gradually increase performance of the vehicle up to the permitted maximum speed, where road conditions permit.

Running-in for brakes

To ensure that the brake pads can 'bed-in' evenly and reach their optimum wear and performance condition, usually within 300 miles (480 kilometres), the following points are recommended:

1. Where possible, avoid heavy braking or rough usage of the brakes as this can result in damage being caused to the brake pads and discs.

2. Avoid prolonged use of the brakes, for example, when descending severe gradients.
3. Frequent light application of the brakes is desirable. This helps to fully 'bed-in' the brake pads before the normal running-in period is completed and the vehicle is operated at high speeds, when maximum brake efficiency will be required.

The above equally applies when new discs or pads have been fitted.

Engine oil consumption

A certain amount of oil consumption is normal. The rate of consumption will depend on the following:

- The quality and viscosity of the oil.
- The amount of oxidation and dilution of the oil.
- Climatic conditions.
- The speed at which the engine is being operated.
- Road conditions.

Drivers should expect above normal consumption when the engine is new, and after running-in if high speeds are sustained.

Winter driving

Freeing a frozen door lock

Caution: Do not apply a proprietary lock de-icer through the keyhole.

Should the lock become frozen, warm the end of the key before use.

Windscreen wiper blades

Before driving away, clear any ice from the windscreen and check that the wiper blades are free. Switching on the heated screen will accelerate this process.

Frost precautions

The correct concentration of coolant must be maintained at all times when 'replenishing' or 'refilling' the cooling system.

Touring

Foreign travel

Before planning foreign travel, check with a motoring organisation to ensure that your vehicle will comply with legal requirements of the countries you intend to visit.

International motoring organisations are helpful for all aspects of long distance touring advice.

In some countries it is a legal requirement to carry spare vehicle bulbs.

First aid kit

A first aid kit is compulsory equipment in certain countries. Your Jaguar Dealer can supply a first aid kit.

Petroleum spirit in containers

Some countries forbid the carrying of petrol in containers, as do most ferry and hovercraft operators.

Cellular radio telephones

Ask your motoring organisation about the use of cellular radio telephones before travelling abroad, as some countries exercise controls on the importation and use of such equipment.

Trunk-rack

Only the Jaguar approved trunk-rack should be used.

The maximum load, including the weight of the rack, must not exceed the load rating indicated on the trunk-rack bars and **must** be deducted from the vehicle maximum luggage load.

Loads on the trunk-rack may affect vehicle handling, especially in crosswinds or when cornering.

Jaguar warning triangle

A warning triangle, designed to international standards, to give traffic advanced notice of a disabled vehicle is compulsory in many countries.

Hazard warning lights must be used with the warning triangle.

The warning triangle with its stand legs folded flat (if fitted), is mounted on the inside of the luggage compartment lid.

In an emergency, remove the triangle and unfold its stand legs. Place the triangle in the road in accordance with local traffic regulations to give oncoming traffic warning of an immobilised vehicle.

